

BRIFEN[®]

MASH Wire Rope Safety Barrier



Product & Installation Manual

Ref: PM 028/02

Table of Contents

1.0	Introduction	5
2.0	Specifications	5
3.0	Crash Test Performance	6
4.0	Crash Test Results	7
4.1	Length-of-Need	7
4.2	Non-Release End Terminal	7
5.0	Design Considerations	8
5.1	Site Grading	8
5.2	Kerbs	8
5.3	Batter Hinge Point	8
5.4	Clearance to Hazards	8
5.5	End Terminal	8
5.6	Transitions to other Safety Barriers	8
5.7	The Point-of-Need	9
5.8	Maximum Length	9
5.9	Horizontal Radius	9
5.10	Vertical Radius	9
5.11	Flare Rate	9
5.12	Post Footing Size	9
5.13	Anchor Block Size	9
6.0	Brifen Component Identification	10
7.0	Tools Required	12
7.1	Recommended PPE	12
8.0	Site Establishment	12
8.1	Traffic Control	12
8.2	Underground Obstructions	12
8.3	Overhead Obstructions	12

8.4	Unloading Exclusion Zone.....	12
9.0	Installation Sequence	13
9.1	Constructing the Anchor Block	13
9.2	Constructing the Terminal Post Footings	15
9.3	Constructing the Length-of Need Post Footings	15
9.4	Installing the Posts	16
9.5	Installing the Cables.....	17
9.6	Tensioning the Cables	22
9.7	Installation Tolerances	23
	Brifen Tension Log.....	24
	Brifen Inspection Form	25
10.0	Maintenance.....	27
11.0	Repair	27
12.0	Dismantling	27
12.2	Recycling	28

Leading Safety

Crash tested in accordance with MASH Test Level 3

Complies with AS/NZS 3845.1:2015 Road safety barrier systems and devices

Recognised as the world's leading wire rope safety barrier

Interwoven feature reduces dynamic deflection

Interwoven feature improves performance for secondary impacts

Non-release terminal end allows the system to remain anchored following design impacts

Impact Performance

Crash tested with posts spaced at 2.1m and 6.4m

All seven (7) mandatory crash tests performed on the non-release terminal end

Soft vehicle containment and redirection through the length-of-need section

Tubular post design eliminates sharp edges

Fast Assembly & Repair

Posts are placed within sockets to facilitate ease of removal following impact

No machinery required for tensioning of cables

Durable

Hot dip galvanised components

Machine swaged end fittings

1.0 Introduction

Easily identified by its unique weave pattern, Brifen Wire Rope Safety Barrier comprises four (4) tensioned wire ropes supported by round steel posts.

Each steel post is supported by a concrete footing, which contains a plastic void to facilitate ease of installation and repair.

Brifen may be installed on the shoulder (verge) or in the median to prevent dangerous cross-over impacts. During impact the errant vehicle is restrained as the tensioned cables deflect. The posts yield by bending proximate to ground level.

The weave pattern limits dynamic deflection by transferring loads to the supporting posts upstream and downstream of the impact zone.

2.0 Specifications

Length of Need:

4 wire ropes supported by 1270mm round posts, 300mm embedment depth into 300mm diameter x 900mm deep concrete footings.

Rope heights of 890mm, 710mm, 530mm and 355mm.

End Terminal:

11.25m non-release, tapered terminal with anchor plate cast into 3m long x 1m deep x 1.5m wide concrete block.

System Finish:

Hot dip galvanised steel posts and anchor plates, pre-stretched galvanised wire rope, UV stabilised post fittings, machine swaged galvanised fittings.



3.0 Crash Test Performance

Brifen has been fully crash tested and assessed in accordance with Test Level 3 (TL3) of the AASHTO Manual for Assessing Safety Hardware (MASH). The MASH specification is an update to and supersedes NCHRP Report 350 for the purposes of evaluating new safety hardware

MASH is also the basis of testing procedures for road safety systems as stated in AS/NZS 3845.1: 2015 Road Safety Barrier System and Devices.

The introduction of MASH follows changes to the vehicle fleet that has increased in weight and height.

Major differences between MASH and NCHRP Report 350 for the evaluation of wire rope barriers include;

- The small car has increased from 820kg to 1100kg;
- The pick-up truck has increased from 2000kg to 2270kg;
- The impact angle for the terminal length-of-need test is increased from 20 degrees to 25 degrees. This increases impact energy by 73%;
- A minimum test length of 183m is required;
- Cable tension is required to be set to the value recommend for 38° Celsius (100° F); and
- Cable splices are required to be installed within the impact region during testing.

Wire rope barrier crash testing performed in accordance with the superseded NCHRP Report 350 was often undertaken on short installation lengths and with cable tensions set to the maximum values thereby producing lower deflection results. These crash test configurations did not adequately represent field installations that were installed over longer lengths and with variable cable tensions.

The set-up required for MASH crash test evaluation is designed to represent worst case scenario for a real-life impact and produce maximum values for dynamic deflection.



MASH 1100kg Passenger Car



MASH 2270kg Pick-up Truck

4.0 Crash Test Results

4.1 Length-of-Need

Post Spacing	Cable Tension	Installation Length	Impact Condition	Dynamic Deflection
2.1m	14 kN (avg)	187m	1100kg passenger car travelling at 100km/h and 25 degrees	1.6m
2.1m	14 kN (avg)	187m	2270kg pick-up travelling at 100km/h and 25 degrees	2.4m
6.4m	12.7 kN (avg)	187m	2270kg pick-up travelling at 100km/h and 25 degrees	3.6m

4.2 Non-Release End Terminal

MASH Reference	Impact Location	Impact Condition	Result
3-30	Nose of the terminal	1100kg passenger car travelling at 100km/h and 0 degrees	PASS
3-31	Nose of the terminal	2270kg pick-up travelling at 100km/h and 0 degrees	PASS
3-32	Nose of the terminal	1100kg passenger car travelling at 100km/h and 15 degrees	PASS
3-33	Nose of the terminal	2270kg pick-up travelling at 100km/h and 15 degrees	PASS
3-34	Terminal Post #3 (Deflection Post)	1100kg passenger car travelling at 100km/h and 15 degrees	PASS
3-35	Terminal Post #3 (Deflection Post)	2270kg pick-up travelling at 100km/h and 25 degrees	PASS
3-37	Terminal Post #3 (Deflection Post) Reverse Impact	1100kg passenger car travelling at 100km/h and 25 degrees	PASS

5.0 Design Considerations

5.1 Site Grading

It is recommended that the area in advance of the barrier and terminal be limited to a grading of 10H:1V and free of undulations that may adversely affect the trajectory of an errant vehicle.

5.2 Kerbs

Placing kerbs in front of the barrier or terminal is not recommended. As an alternative subsurface grated drainage should be considered.

5.3 Batter Hinge Point

The recommended minimum offset from the barrier to the batter hinge point is 2.4m. This is the recorded deflection with posts installed at 2.1m centres when impacted with a 2270kg pick-up travelling at 100km/h and 25 degrees.

5.4 Clearance to Hazards

Under impact the system will deflect as the errant vehicle is contained and redirected.

Sufficient space shall be provided behind the barrier to accommodate the expected deflection of the system.

Deflection results are provided in Section 4.1.

Brifen may be stiffened in advance and adjacent to a fixed hazard by reducing the post spacing. Contact Safe Direction for details.

5.5 End Terminal

The Brifen terminal is required on the leading and trailing end of the system and features an anchor bracket cast into a concrete block.

The Brifen terminal has been crash tested in accordance with MASH TL3 and gradually tapers the cables from full height to an anchor plate located at ground level over a length of 11.25m.

The Brifen terminal is a non-release terminal. The non-release feature allows the system to remain anchored following design impacts.

When struck at the end, the Brifen terminal will yield. Consideration should be given to ensure the area immediately behind the terminal is traversable and free of fixed object hazards.

The MASH TL3 test matrix for wire rope end terminals requires a reverse direction impact. The successful outcome of this test provides suitability of the Brifen terminal at the leading and trailing end of the wire rope system.

The Brifen terminal may be impacted from either side making it suitable for median installations.

5.6 Transitions to other Safety Barriers

Brifen shall not be directly connected to other safety barrier systems.

Brifen may be interfaced with other safety barrier systems by overlapping barriers with sufficient clearance between them to ensure neither barrier adversely affects the performance of the other and overlapping is sufficient to allow a continuous 'length of redirection'.

5.7 The Point-of-Need

This is the location along the terminal that has demonstrated complete vehicle containment and re-direction. When assessed for MASH TL3 conditions, this impact is performed with a 2,270kg pick-up truck travelling at 100km/h and impacting at 25°.

The Brifen terminal point-of-need is post location 3, referred to as the Deflection Post, a distance of 11.25m downstream from the cast-in position of the anchor plate.

5.8 Maximum Length

There is no theoretical limit if the system is installed on a straight alignment with no major horizontal or vertical curves.

Australian State Road Agencies may have maximum length restrictions in consideration of maintenance and emergency vehicle access.

5.9 Horizontal Radius

The recommended minimum horizontal radius is 200m.

5.10 Vertical Radius

The recommended minimum sag vertical curve (K value) is ≥ 30 m.

$$K = \frac{\text{length of vertical curve (metres)}}{\text{the change in grade (\%)}}$$

5.11 Flare Rate

The recommended maximum flare rate of the barrier is 30:1.

5.12 Post Footing Size

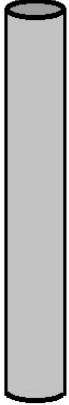
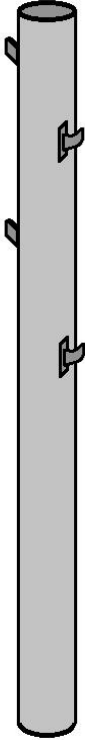
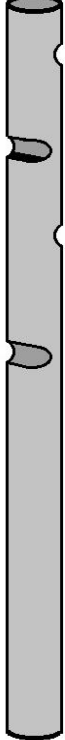
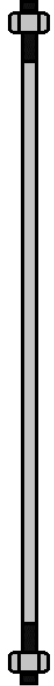
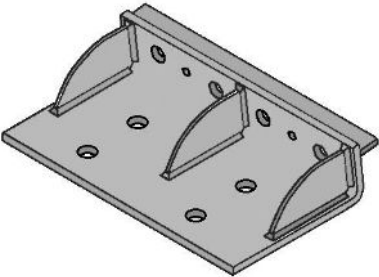
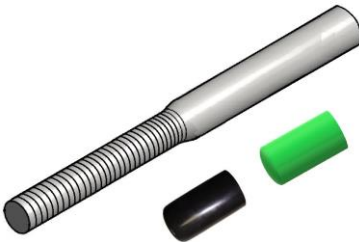
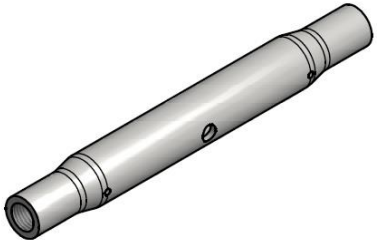
The recommended post footing size is 300mm diameter x 900mm deep for installation in firm soils or stronger.

5.13 Anchor Block Size


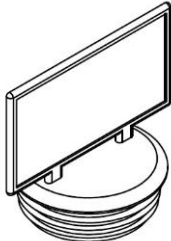
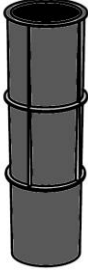





The recommended anchor block size is 3m long x 1m deep x 1.5m wide for installation in firm soils or stronger.



6.0 Brifen Component Identification

			
<p>Terminal Post #1 & #2</p>	<p>Deflection Post</p>	<p>Line Post</p>	<p>Anchor Bolt</p>
			
<p>Anchor Plate</p>	<p>Swage Fitting Black Cap: Left Hand Thread Green Cap: Right Hand Thread</p>		<p>Rigging Screw</p>

Brifen Component Identification (cont.)

		
<p>Post Cap</p>	<p>Post Cap with Delineator</p>	<p>Post Sleeve</p>
		
<p>Post Footing Reo Ring</p>	<p>Ground Cover</p>	<p>Cable Retainer</p>
		
<p>Cable Grip</p>		<p>Tension Meter</p>

7.0 Tools Required

Tools required for the installation of Brifen include;

- Auger or excavating machinery;
- Concrete trowel;
- String line;
- Tape measure;
- Spirit level;
- Wire rope grips;
- Tension meter;
- Ring spanner; and
- Swaging machine.

7.1 Recommended PPE

It is recommended that the following personal protective equipment (PPE) be provided for the safe installation of Brifen;

- Safety footwear;
- Gloves;
- Hearing protection; and
- High visibility clothing.

8.0 Site Establishment

8.1 Traffic Control

Prior to the commencement of any work, the site should be evaluated for risks to workers, pedestrians and other road users. The establishment of traffic control should provide safe travel for passing vehicles and/or pedestrians and appropriately protect workers near the roadside.

8.2 Underground Obstructions

The site should be evaluated for potential underground obstructions that may present a risk during auguring or soil excavation.

8.3 Overhead Obstructions

The site should be evaluated for potential overhead obstructions that may present a risk during the installation process. These obstructions typically include power lines, signage or trees.

8.4 Unloading Exclusion Zone

Only appropriate load-rated slings or chains should be used for safe unloading. It is recommended that an exclusion zone be maintained around the unloading process. This provides distance between moving machinery and workers in the event that goods or the machinery move unexpectedly.

Unloading and the storing of the product on a level surface is recommended. Storing product adjacent to the installation area eliminates the requirement for workers to carry items over long distances.

9.0 Installation Sequence

The major steps in the installation of Brifen are as follows;

- Constructing the end anchors;
- Constructing the post footings;
- Installing the terminal posts;
- Installing the length-of-need posts;
- Installing the wire cables; and
- Tensioning the wire cables.

The anchor system is 11.25m and comprises three (3) posts and an anchor plate.

9.1 Constructing the Anchor Block

Potential Hazards: deep excavation, movements from machinery.

Recommended Control Measures: Maintain an exclusion zone around moving machinery, do not leave deep excavations unattended.

1. Establish the location of the anchor block ensuring the centre of the anchor block is aligned with the downstream barrier.
2. Excavate in accordance with Safe Direction drawings and remove spoil. The walls of the excavation shall be vertical.
3. Attach the four (4) anchor rods to the anchor plate.
4. Suspend the anchor plate and reo-mesh using temporary support frames. The bottom of the anchor plate shall be level with the top of the anchor block.
5. Place concrete to the level of the anchor plate and vibrate.
6. Trowel the surface to ensure a level finish with the anchor plate.
7. The recommended minimum curing time for the anchor block is 7 days. The concrete shall have a minimum 28-day strength of 25MPa.
8. Once the anchor block has cured tighten the four (4) anchor rod nuts.



Figure 1: Placement of Anchor Plate



Figure 2: Inserting Anchor Bolts



Figure 3: Levelling Anchor Plate



Figure 4: Final Position of Anchor Plate

9.2 Constructing the Terminal Post Footings

Potential Hazards: deep excavation, movements from machinery.

Recommended Control Measures: Maintain an exclusion zone around moving machinery, do not leave deep excavations unattended.

1. Using a string line starting at the centre of the anchor plate position, establish the position of the terminal posts.
2. Terminal Post #1 is 4000mm from the anchor plate.
3. Terminal Post #2 is 4000mm from Terminal Post #1.
4. Terminal Post #3, known as the Deflection Post is 3200mm from Terminal Post #2.
5. Using a 300mm diameter auger, drill the post footings to a depth of 900mm and remove spoil.
6. Pour concrete into the hole to within 50mm of the finished surface level.
7. Place the reo ring in the centre of the post hole.
8. Insert the post socket through the reo ring ensuring the top of the sleeve is aligned with finished surface level.

9. Fill the remainder of the hole to finished surface level.
10. Insert a post into the socket and use a spirit level to ensure the sleeve is aligned vertically.
11. Remove the post from the socket and place across the top of the post footing and socket to prevent flotation of the sleeve as the concrete cures. The socket will remain in place with no pressure after approximately 20 minutes.
12. The recommended minimum curing time for the post footings is 7 days. The concrete shall have a minimum 28-day strength of 25MPa.

9.3 Constructing the Length-of-Need Post Footings

Potential Hazards: deep excavation, movements from machinery.

Recommended Control Measures: Maintain an exclusion zone around moving machinery, do not leave deep excavations unattended.

1. Using a string line, establish the position and spacing of the post footings. The post spacing is project specific and dependent upon the maximum allowable deflection. Refer to Section 5.4.
2. Repeat the steps 5 to 12 as described in Section 9.2.



Figure 5: Post Hole with Post Sleeve and Reo Ring

9.4 Installing the Posts

Potential Hazards: Injury from movements and posture, hand injury from pinch points.

Recommended Control Measures: Observe correct techniques (bend at the knees), wear gloves.

There are three (3) terminal posts;

- Terminal Post #1, 715mm long, positioned 4000mm from the anchor bracket;
- Terminal Post #2, 1000mm long, positioned 4000mm from Terminal Post #2; and
- Terminal Post #3, also known as the Deflection Post, 1270mm long, positioned 3200mm from the Terminal Post #2. This post has four (4) staggered, protruding pins that position each of the four (4) wire cables.

Each Length-of-Need Post, also known as Line Posts, are 1270mm long and feature four (4) recesses on the side of the post.

1. Slide a ground cover over the bottom of each post.
2. Beginning at the terminal, insert the terminal posts into their respective sockets. The posts should gradually taper upwards to full height.
3. The Deflection Post is orientated with the top protruding pin on the traffic side.
4. The first length-of-need post will have the opposite orientation to the deflection post i.e. the top recess is on the non-traffic side.
5. Continue to insert the Line Posts into their respective sockets.
6. The orientation of each subsequent Line Post is a reverse orientation of the previous post.
7. Ensure the position of the ground covers is at the base of each post.



Figure 6: Installation of Line Posts

9.5 Installing the Cables

Potential Hazards: Injury from movements and posture, hand injury from pinch points.

Recommended Control Measures: Observe correct techniques (bend at the knees), wear gloves.

The installation of wire cables should not commence until the concrete anchor blocks and post footings have cured.

The system will require rigging screws spaced at a maximum 300m throughout the barrier. A fence longer than 300m will require multiple rigging screws per cable.

Rigging screws shall not be located within the terminal section.

Prior to installing the cables mark-out the proposed location of the rigging screws.

1. Starting at the end anchor nearest to approaching traffic, machine swage a right-hand end fitting (green cap) to the first cable and secure to the furthest hole of the anchor bracket (observed from the traffic side) and fasten with two (2) nuts and one (1) washer. This becomes Rope 1 (the bottom rope).

Note: At least three (3) threads of the end fitting should show through the locking nut.

2. Using a truck or trailer fitted with a cable reel frame, pull the cable towards the location of the first rigging screw.
3. Rope 1 will pass Terminal Post #1 on the non-traffic side.
4. Rope 1 will pass Terminal Post #2 on the traffic side.

Note: Terminal Posts #1 and #2 do not have protruding pins or recesses. The wire rope will simply rest against the side of these posts as they taper up to full height.

Rope 1 will rest on the lower protruding pin of the Deflection Post.

5. Rope 1 is positioned in the bottom recess of the Line Posts.
6. At each Line Post use a retainer clip to secure the position of the rope within the post recess.

The retainer clip features a zip tie that clamps around the post. The retainer clip is positioned above the cable with the finger of the clip holding the cable in position against the post slot.



Figure 7: Rope Located within Recess of Line Post before Attachment of Retainer Clip



Figure 8: Retainer Clip



Figure 9: Securing of Retainer Clip



Figure 10: Retainer Clip Position

7. At the location of the rigging screw, ensure the cable slack is removed and temporarily clamped.
8. Cut the rope and machine swage a right-hand end fitting (green cap).
9. Attach a rigging screw to the end fitting, ensuring at least 25mm of thread is secured.

Note: It is recommended that the rigging screws be lubricated using a copper anti-seize lubricant to facilitate ease of adjustment and/or removal during maintenance or repair.

10. Machine swage a left-hand end fitting (black cap) and secure to the other end of the rigging screw ensuring that at least 25mm of thread is secured.
11. Continue to run out the rope to the next rigging screw location or anchor, whichever comes first.

Note: When the cable reel is depleted, machine swage a right-hand fitting and attach to the new reel with a rigging screw and left-hand fitting observing the same method described in Steps 10 & 11.

This splice connection now becomes a rigging screw location.

12. Repeat the process of weaving and securing the rope with retainer clips on the bottom recess of the Line Posts until reaching the trailing end anchor.

Note: The rope position on the Deflection Post and Terminal Posts may be opposite to the leading anchor as this is determined by the weave pattern of the Line Posts.

13. At the trailing anchor, ensure the cable slack is removed from the rope along the system using a cable clamp and winch before temporarily clamping.

14. Machine swage a right-hand end fitting (green cap) to the rope and secure to the furthest or nearest hole of the anchor bracket (depending upon the weave pattern) and fasten with two (2) nuts and one (1) washer.

Note: At least three (3) threads of the end fitting should show through the locking nut.

15. Repeat with Rope 2 using the opposite weave pattern to Rope 1

16. Repeat with Rope 3 using the same weave pattern to Rope 1.

17. Repeat with Rope 4 using the same weave pattern to Rope 2.

18. Insert post caps into the top of each post. A delineator post cap is spaced as per project requirements.

19. Attach delineation to the post cap as required.

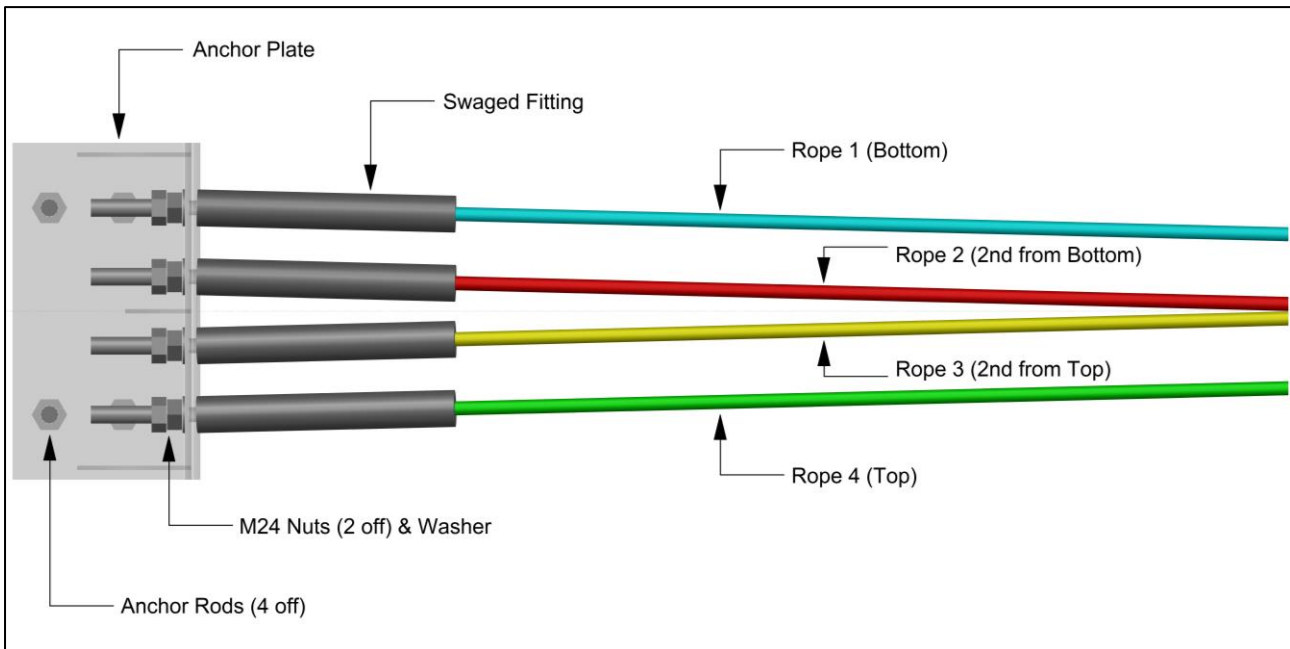


Figure 11: Rope Connection at Leading Anchor



Figure 12: Anchor Bracket Assembly



Figure 13: Cable Weave at Terminal



Figure 14: Deflection Post Assembly



Figure 14: Line Post Assembly

9.6 Tensioning the Cables

Potential Hazards: Hand injury from pinch points.

Recommended Control Measures: Wear gloves.

Ensure that all rigging screws have a minimum thread engagement of 25mm and that the cable slack has been removed from the ropes. Check that each rope is securely fastened to the anchor bracket as described in section 9.5.

1. In the bay adjacent to the tension bay, place the tension meter on the top rope, ensuring all three (3) rollers of the meter are engaged with the rope.
2. The centre roller will deflect the rope once the lever arm is locked into position and the rope tension will be displayed.
3. The required rope tension is dependent on temperature of the cable. The temperature may be measured as follows;
 - Using an infrared thermometer aimed at the rope being tensioned; or
 - Measuring the ambient air temperature.
4. Adjust the rigging screw by turning until the desired rope tension has been reached. The two swaged fittings should be held steady with wrenches whilst the rigging screw is rotated.
5. Release the tension meter lever arm and repeat the process with subsequent cables.
6. It is recommended that the temperature and tension of each rope be recorded as detailed in the Brifen Tension Log.
7. Proceed along the fence to each rigging crew location and repeat procedure.

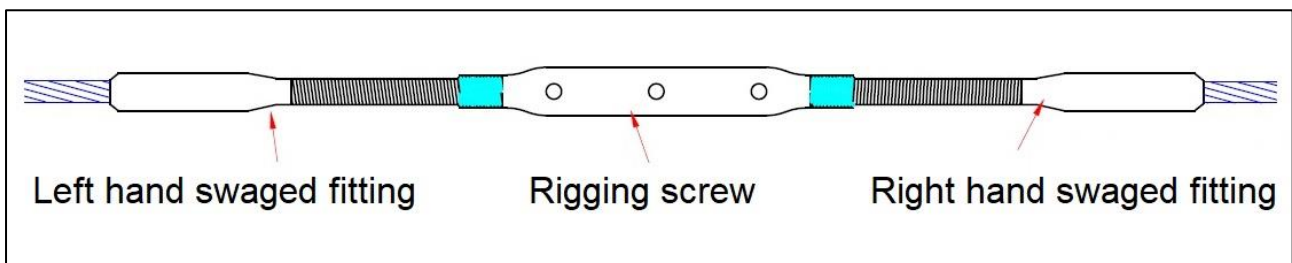


Figure 15: Rigging Screw Assembly

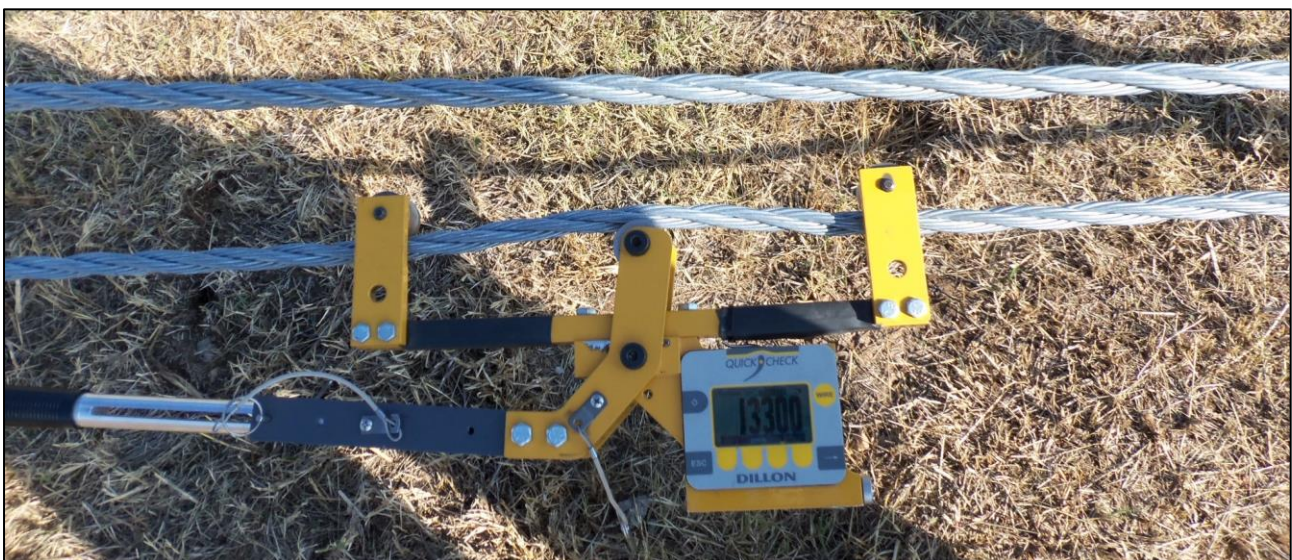


Figure 16: Tension Meter Attachment

9.7 Installation Tolerances

Description	Tolerance
Concrete Post Footings.	not more that 75mm above ground line.
Post Sleeve.	± 25mm to the ground line.
Post Alignment.	75mm maximum from vertical alignment, measured at top of post.
Rope 1 Height (Bottom Rope).	355mm ± 25mm.
Rope 2 Height (2 nd from Bottom Rope).	530mm ± 25mm.
Rope 3 Height (3 rd from Bottom Rope).	710mm ± 25mm.
Rope 4 Height (Top Rope).	890mm ± 25mm.
Tension Bay Positions.	not more that 300m apart.
Rope Tension.	± 20%



Brifen Tension Log

Date	
Client	
Project Reference	
Fence Reference	
Name of Inspector	
Company	

Temperature (°C)	-15	-10	-5	0	5	10	15	20
Rope Tension (kN)	24.7	23.5	22.3	21.1	19.9	18.7	17.4	16.3

Temperature (°C)	25	30	35	40	45	50	55	60
Rope Tension (kN)	15.1	13.9	12.7	11.5	10.3	9.0	7.9	6.7

	Tension Bay number:			Tension Bay number:		
	Temperature (°C)	Required Tension (kN)	Actual Tension (kN)	Temperature (°C)	Required Tension (kN)	Actual Tension (kN)
Top Rope						
2 nd rope						
3 rd Rope						
Bottom Rope						

	Tension Bay number:			Tension Bay number:		
	Temperature (°C)	Required Tension (kN)	Actual Tension (kN)	Temperature (°C)	Required Tension (kN)	Actual Tension (kN)
Top Rope						
2 nd rope						
3 rd Rope						
Bottom Rope						

Brifen Inspection Form

Inspection Date	
Client	
Project Reference	
Fence Reference	
Name of Inspector	
Company	

End Terminals	
<input type="checkbox"/> Yes <input type="checkbox"/> No	The top of the anchor plate is level with the top of the concrete anchor block.
<input type="checkbox"/> Yes <input type="checkbox"/> No	The anchor plate is aligned with the centreline of the downstream barrier.
<input type="checkbox"/> Yes <input type="checkbox"/> No	Each end fitting is secured to the anchor plate with two (2) nuts and one (1) washer.
<input type="checkbox"/> Yes <input type="checkbox"/> No	There are least three (3) threads of the end fitting showing through the locking nut.
<input type="checkbox"/> Yes <input type="checkbox"/> No	Terminal Post #1 is 4000mm from the anchor bracket.
<input type="checkbox"/> Yes <input type="checkbox"/> No	Terminal Post #2 is 4000mm from Terminal Post #1.
<input type="checkbox"/> Yes <input type="checkbox"/> No	Terminal Post #3 (Deflection Post) is 3200mm from Terminal Post #2.
<input type="checkbox"/> Yes <input type="checkbox"/> No	The ropes are terminated at the anchor in the correct orientation as per SD drawings.
Posts	
<input type="checkbox"/> Yes <input type="checkbox"/> No	The Line Posts are spaced as per project requirements.
<input type="checkbox"/> Yes <input type="checkbox"/> No	The top of each concrete footing is not more than 75mm above ground line.
<input type="checkbox"/> Yes <input type="checkbox"/> No	Each post is installed in a post socket.
<input type="checkbox"/> Yes <input type="checkbox"/> No	The top of each post socket is \pm 25mm to the ground line.
<input type="checkbox"/> Yes <input type="checkbox"/> No	Each post is fitted with a ground cover.
<input type="checkbox"/> Yes <input type="checkbox"/> No	Each rope is secured at each Line Post with a retainer clip.
<input type="checkbox"/> Yes <input type="checkbox"/> No	A cap is installed on each post.
<input type="checkbox"/> Yes <input type="checkbox"/> No	Delineation has been attached to the post caps as per project requirements.

10.0 Maintenance

Brifen is a low maintenance barrier. Except for repairs due to impacts, it is recommended that an annual inspection be undertaken to assess the following;

- Debris has not accumulated around the barrier which may impede the function of the barrier;
- Vegetation around the barrier is appropriately maintained;
- Nuisance impacts have not gone undetected;
- Post caps have not dislodged; and
- The system is appropriately delineated.

11.0 Repair

In the event of an impact, damage to the Brifen system is to be assessed in accordance with Table 1. Only genuine Brifen components supplied by Safe Direction shall be used for repair.

If an impact is within 50m of the end terminal then the Deflection Post and end anchor should be inspected for damage.

In the unlikely event that, following a vehicle impact it is necessary to remove the Brifen ropes to assist in vehicle recovery, **do not cut the ropes under tension.**

Reduce the tension in the ropes by loosening the nearest rigging screws. Secure the swaged fittings either side of the rigging screw with wrenches before turning the rigging screw using a third wrench. It may be necessary to completely unscrew the rigging screws on both sides of the accident.

The wire ropes are pre-stretched prior to installation which removes construction slack. During vehicle impact the ropes may be subjected to additional stretching as the individual wire strands move closer together within the wire rope.

It is therefore recommended that rope tension be checked following vehicle impacts.

When the swaged fittings connecting the rigging screws are damaged after a vehicle impact, longer length rigging screws are available to facilitate on-site replacement of either one or both swaged fittings without the need to replace a section of wire cable.

Due to work hardening of the end fittings and rigging screws, it is not acceptable to straighten these items if damaged following a vehicle impact.

If the post has been knocked down and the post foundation is undisturbed, then the damaged post shall be removed and replaced.

If the post foundation is damaged, it will require replacement.

The weave pattern of the fence must be maintained following repair. Extra posts shall not be installed that will alter the weave pattern.

12.0 Dismantling

The installation of posts in concrete sockets facilitates ease of dismantling. In the event that the Brifen fence requires to be dismantled the following sequence is recommended;

1. Reduce the tension in the ropes by loosening the rigging screws. Secure the swaged fittings either side of the rigging screw with wrenches before turning the rigging screw using a third wrench.
2. Using a screw driver, lift the finger of the retainer clip and remove the cable from the post recess and lay the cable on the ground.
3. Remove the posts from their sockets. It may be necessary to impact the base of each post with a sledge hammer to loosen.
4. If required, remove the cables from the anchor bracket by loosening and removing the securing nuts.
5. If disposing of the fence, it may be necessary to cut the cables using a disk grinder into smaller sections for ease of handling.

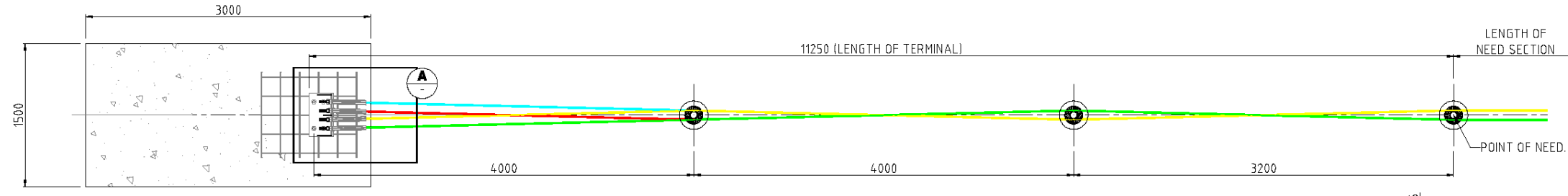
12.2 Recycling

- Brifen posts, rigging screws and wire cable are manufactured from galvanised steel may be recycled.
- Brifen plastic fittings manufactured from HPPE are 100% recyclable.

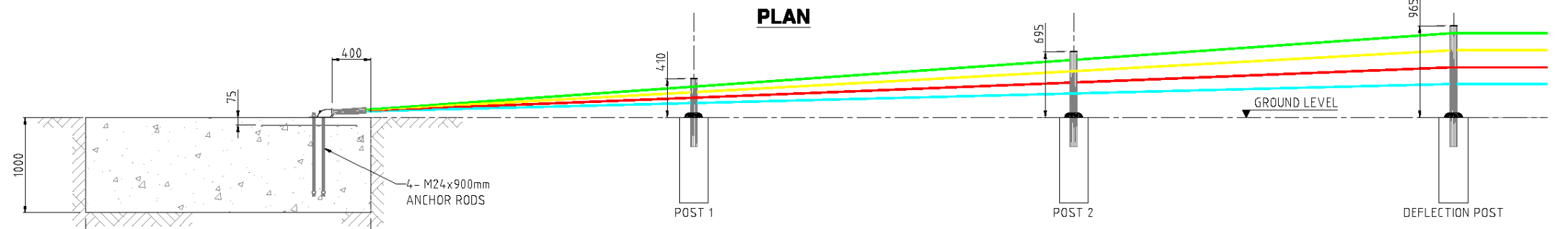


Table 1: Brifen Damage Assessment Guidelines

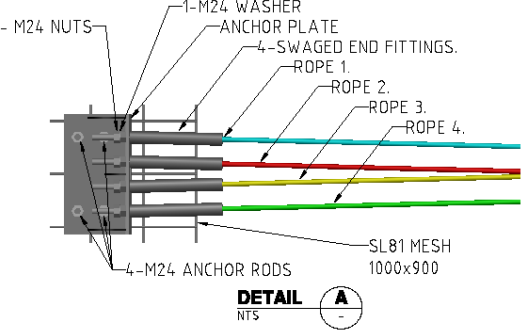
Type of Damage	Description of the Damage	Remedial Action
Galvanised damage to posts.	The sum total of the damaged area does not exceed 150cm ² (0.5% of the total surface area) and no individual damaged area exceeds 40cm ² .	An organic zinc rich paint is to be applied to the repair area in two coats.
	The sum total of the damaged exceeds 150cm ² (0.5% of the total surface area) and no individual damaged area exceeds 40cm ² .	The post is to be replaced.
Galvanised damage to wire cable.	There is minor damage to the surface associated with contact against the posts during installation.	An organic zinc rich paint is to be applied to the repair area in two coats.
	There is a broken wire.	The wire cable section is to be replaced.
Damage to posts.	The post is bent or distorted.	The post is to be replaced.
	The protruding pins of the Deflection Post are damaged.	
Damage to wire cable.	The wire rope is bent or distorted.	The wire rope is to be replaced.
	Any strand of the wire cable is broken.	
Damage to end fittings.	The end fitting is deformed.	The end fitting is to be replaced.
	The thread of the end fitting is damaged.	
Damage to rigging screws.	The body of the rigging screw is cracked or distorted.	The rigging screw is to be replaced.
Damage to post fittings.	The ground cover is deformed, split or cracked.	The item is to be replaced.
	The post cap is deformed, split or cracked.	
	The cable retainer is deformed, split or cracked.	



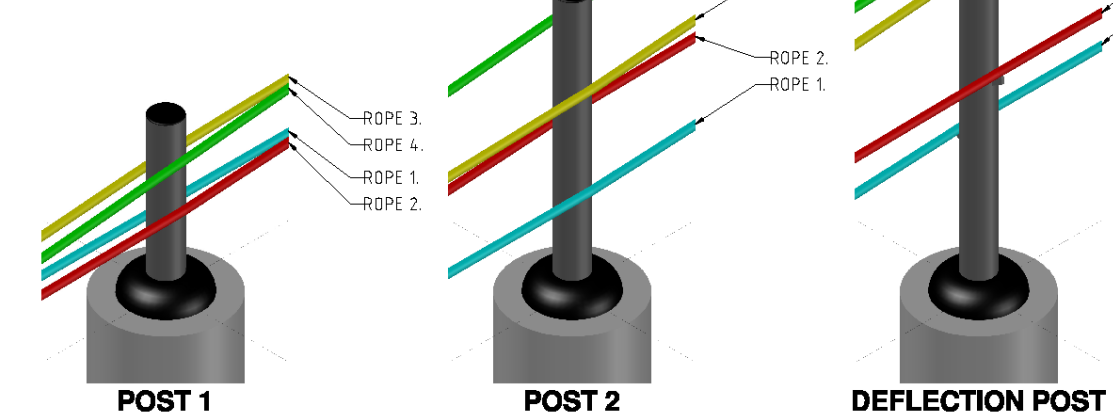
PLAN



ELEVATION



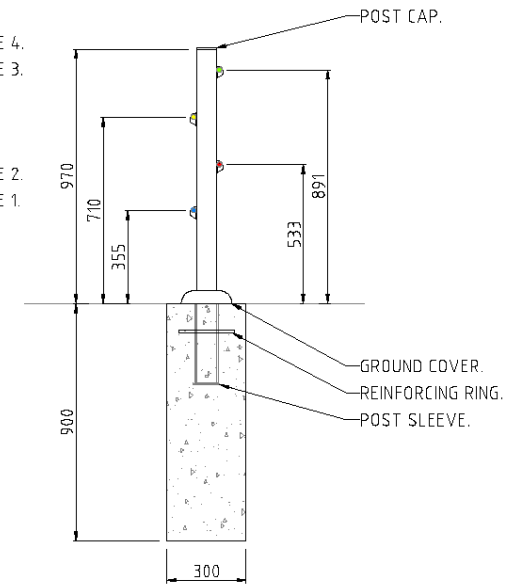
DETAIL A



POST 1

POST 2

DEFLECTION POST



DEFLECTION POST (ELEVATION)

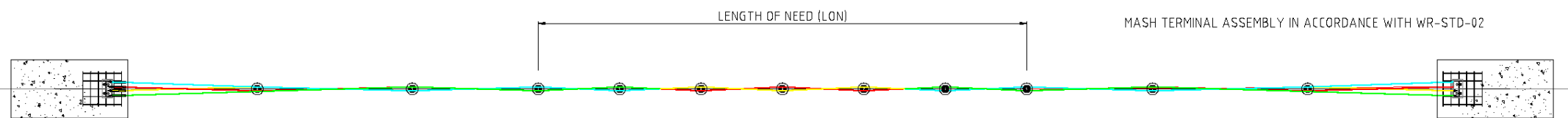
- NOTES:**
1. DIMENSIONS IN MM.
 2. ALL FOUNDATION DEPTHS TO BE MEASURED FROM ADJACENT GROUND LEVEL.
 3. CONCRETE SHALL HAVE A MINIMUM 28-DAY STRENGTH OF 25MPA.
 4. ALLOWABLE TOLERANCES:
 - A. POST SLEEVE FINISHING HEIGHT: ± 20 MM TO GROUND LEVEL
 - B. ROPE HEIGHT: ± 25 MM
 5. THE ANCHOR PLATE SHALL BE INSTALLED LEVEL. IF THE ANCHOR BLOCK IS INSTALLED ON A CROSS SLOPE, THE PLATE SHOULD BE INSTALLED TO MATCH THE SLOPE.
 6. RIGGING SCREWS (TENSION BAYS) ARE NOT TO BE LOCATED WITHIN THE TERMINAL SECTION.
 7. THE WEAVE ORIENTATION MAY BE REVERSED ON THE TRAILING END DEPENDING ON NUMBER OF POSTS WITHIN THE LENGTH OF NEED SECTION.

REV	DATE	DESCRIPTION	DRAWN	APPRD.
A	27.09.19	INITIAL ISSUE	DB	TC

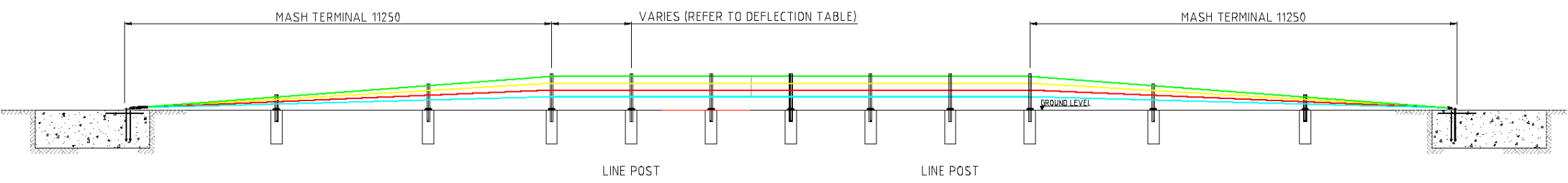
REV	DATE	DESCRIPTION	DRAWN	APPRD.



DRAWING DESCRIPTION	MASH TL3 BRIFEN END TERMINAL				
DRAWING REFERENCE	WR-STD-02	DRAWN BY	AUSTEC DRAFTING	DIMENSIONS	mm
		CHECKED	H. WALLACE	SCALE	NTS
		APPROVED	T. COLQUHOUN		



PLAN



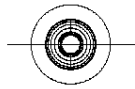
ELEVATION

CRASH TEST DEFLECTION RESULTS TABLE
2270kg PICK-UP TRAVELING AT 100km/h AND 25°

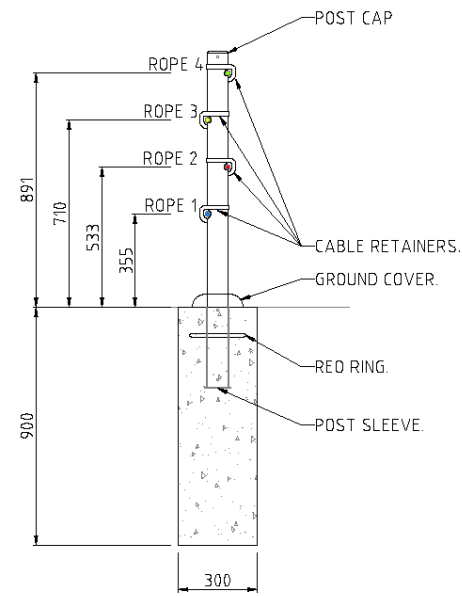
POST SPACING (m)	DEFLECTION (m)
2.1	2.4
6.4	3.6

ROPE TENSION TABLE

TEMPERATURE (°C)	TENSION (kN)
-15	24.7
-1	23.5
-5	22.3
0	21.1
5	19.9
10	18.7
15	17.4
20	16.3
25	15.1
30	13.9
35	12.7
40	11.5
45	10.3
50	9.0
55	7.9
60	6.7



PLAN



ELEVATION
LINE POST DETAIL



TENSION FITTING ASSEMBLY DETAIL

NOTES:

- DIMENSIONS IN mm.
- ALL FOUNDATION DEPTHS TO BE MEASURED FROM ADJACENT GROUND LEVEL.
- CONCRETE SHALL HAVE A MINIMUM 28-DAY STRENGTH OF 25MPA.
- ALLOWABLE TOLERANCES:
 - POST SLEEVE FINISHING HEIGHT: ± 20MM TO GROUND LEVEL.
 - ROPE HEIGHT: ± 25MM.
- RIGGING SCREWS (TENSION BAYS) ARE NOT TO BE LOCATED WITHIN THE TERMINAL SECTION.
- MAXIMUM ALLOWABLE POST SPACING TO BE IN ACCORDANCE WITH STATE ROAD AGENCY SPECIFICATIONS.

REV	DATE	DESCRIPTION	DRAWN	APPRD.	REV	DATE	DESCRIPTION	DRAWN	APPRD.
B	12.03.20	REISSUED INITIAL ISSUE	DB	TC					
A	17.10.19	INITIAL ISSUE	DB	TC					



DRAWING DESCRIPTION	MASH TL3 BRIFEN GENERAL ARRANGEMENT				
DRAWING REFERENCE	WR-STD-03	DRAWN BY	AUSTEC DRAFTING	DIMENSIONS	mm
		CHECKED	H. WALLACE	SCALE	NTS
		APPROVED	T. COLOUHOUN		



SafeDirection
CRASH BARRIER SOLUTIONS



SafeDirection

CRASH BARRIER SOLUTIONS

Safe Direction Pty Ltd

Unit 2, 5 Simpson Close, Smeaton Grange NSW 2567 Australia

Ph: 1300 063 220 | E: sales@safedirection.com.au

safedirection.com.au

ABN 53 156 459 684