

MSKT

Sequential Kinking Terminal
Compliant to MASH Test Level 3



Product & Installation Manual

Table of Contents

1.0	The MSKT	6
2.0	How the MSKT Functions	6
3.0	Crash Test Performance	7
4.0	Set-out	9
4.1	Site Grading Requirements.....	9
4.1.1	Advance Grading.....	9
4.1.2	Adjacent Grading	9
4.1.3	Run-Out Grading.....	9
4.2	The Point-of-Need	9
4.3	Kerbs	10
4.4	Placement in Concrete	10
4.5	Other Obstructions & Hazards	10
4.6	Use of an Offset	10
4.7	Placement on Curves	10
4.8	Length Between Terminals.....	10
5.0	Bill of Materials	16
6.0	Component Identification	17
7.0	Tools Required	19
7.1	Recommended PPE.....	19
8.0	Site Establishment	19
8.1	Traffic Control.....	19
8.2	Underground Services	19
8.3	Overhead Obstructions	19
8.4	Unloading Exclusion Zone.....	19
9.0	Installation Sequence	20
9.1	Set-Out.....	20
9.2	Installation of Hinged Posts 1 & 2	21
9.3	Installation of Steel Line Posts.....	24
9.4	Attaching the Cable Anchor Bracket.....	24
9.5	Attaching the Rails & Blocks	26
9.6	Attaching the Impact Head.....	26
9.7	Installing the Cable Assembly.....	27

9.8	Installation of Impact Head Cover	27
9.9	Attachment of Delineation	27
10.0	Maintenance	33
10.1	Bushfire Damage	33
11.0	Repair.....	33
11.1	Removal of the Impact Head	35
11.2	Removal of Damaged Posts	35
11.3	Removal of Damaged Rails	35
11.4	Emergency Procedure After Impact	36
11.5	Retrofit using MSKT Impact Head.....	36

List of Figures

Figure 1: MASH End Terminal Crash Test Evaluation	8
Figure 2: MSKT Component Identification (TL3)	11
Figure 3: MSKT Set-Out (TL3)	12
Figure 4: MSKT Grading Arrangement	13
Figure 5: Point-of-Need Set-Out	14
Figure 6: Post in Concrete Pavement	15
Figure 7: Post 1 Identification	22
Figure 8: Post 1 Connection Detail	23
Figure 9: Attachment of Cable Ancor Bracket	25
Figure 10: Cable Assembly & Impact Head Assembly Detail	28
Figure 11: MSKT Side View & Impact Head Delineation Options	29
Figure 12: Attachment of Chains for Removal of Impact Head	37

List of Tables

Table 1: Damage Assessment Guidelines	34
--	-----------

List of Drawings

MSKT- TL3 Assembly Drawing	40
MSKT- TL2 Assembly Drawing	39

Leading Safety

Successfully crash tested to MASH Test Level 3

All seven (7) mandatory crash tests performed

Complies with AS/NZS 3845.1:2015 Road safety barrier systems and devices

Assessed for shallow angle (5°) impacts

Higher safe redirection capacity than NCHRP Report 350 Terminals
(the MASH impact represents a 73% energy increase when compared to NCHRP 350 testing)

Impact Performance

Impact energy is dissipated by the sequential kinking process

Slotted anchor rail lowers the impact forces

Longer feeder chute allows the impact head to travel in a more predictable manner
and assists vehicle stability

Compatibility

Designed for attachment directly to w-beam guardrail barrier

The MASH SKT impact head can be used as a replacement item for existing NCHRP
Report 350 compliant SKT terminals

Fast Assembly

Same installation sequence to earlier SKT versions

No concrete required

Stiff driving post sections



1.0 The MSKT

The MASH Compliant Sequential Kinking Guardrail End Terminal (MSKT) is an energy-absorbing, tangential end terminal, designed to minimise the severity of impacts occurring at the end of the safety barrier system.

Designed for attachment directly to w-beam guardrail, the MSKT is latest advancement in guardrail end terminal technology providing compliance with MASH Test Level 3.

The MSKT represents the latest configuration for the SKT terminal that was first introduced in 1997. Since that time the SKT has become one of the world's leading end treatment solutions.

The tangential design feature allows the MSKT to be installed parallel to the roadway reducing the requirement for earthworks and site grading associated with traditional parabolic-flared terminal designs.

The MSKT is available in two configurations. The compact MASH TL2 Terminal is an economical solution where the posted speed is less than or equal to 70km/h. The standard MASH TL3 Terminal is acceptable for all posted speeds greater than 70km/h.

2.0 How the MSKT Functions

The MSKT comprises several unique components integral to the performance of the terminal. These include;

- Slotted anchor rail;
- Impact head;
- Bolted hinged posts;
- Steel line posts; and
- Anchor bracket and cable assembly.

During head-on impacts, the MSKT impact head slides over the w-beam guardrail. The w-beam is sequentially kinked as it moves through the head and exits away from the traffic face. The kinking action of the rail absorbs the kinetic energy of the impacting vehicle bringing the vehicle to a controlled stop.

As the impact head slides over the w-beam guardrail, the bolted hinged posts at post locations 1 and 2 yield at ground level. The yielding action of the hinged posts contributes to a soft impact for vehicle occupants.

The use of steel line posts at post locations 3 and beyond provides the MSKT with the necessary lateral support required for safe vehicle containment and re-direction through the length-of-need section.

3.0 Crash Test Performance

The MSKT has been fully crash tested and assessed in accordance with Test Level 3 (TL3) of the AASHTO Manual for Assessing Safety Hardware (MASH). The MASH specification is an update to and supersedes NCHRP Report 350 for the purposes of evaluating new safety hardware devices.

MASH is also the basis of testing procedures for road safety systems as stated in *AS/NZS 3845.1: 2015 Road Safety Barrier System and Devices*.

The introduction of MASH follows changes to the vehicle fleet that has increased in weight and height.

Major differences between MASH and NCHRP Report 350 for the evaluation of guardrail end terminals include;

- The small car has increased from 820kg to 1100kg;
- The pick-up truck has increased from 2000kg to 2270kg;
- The impact angle for length-of-need testing is increased from 20 degrees to 25 degrees. This increases impact energy by 73% for the pick-up truck test; and
- The impact angle for oblique end impacts is reduced from 15 degrees to 5 degrees.

Shallow angle impact performance, considered representative of real-life crash test impacts, has been identified as a limitation within the NCHRP Report 350 test matrix.

The US Federal Highway Administration (FHWA) no longer reviews nor accepts requests for product evaluation for revised or new safety barrier products unless they have met the requirements of MASH.



MASH 1100kg Small Car



MASH 2270kg Pick-up Truck



MASH Test 3-31 Set-Up (2270P at 100km/h and 0°)



MASH Test 3-33 Set-Up (2270P at 100km/h and 5°)

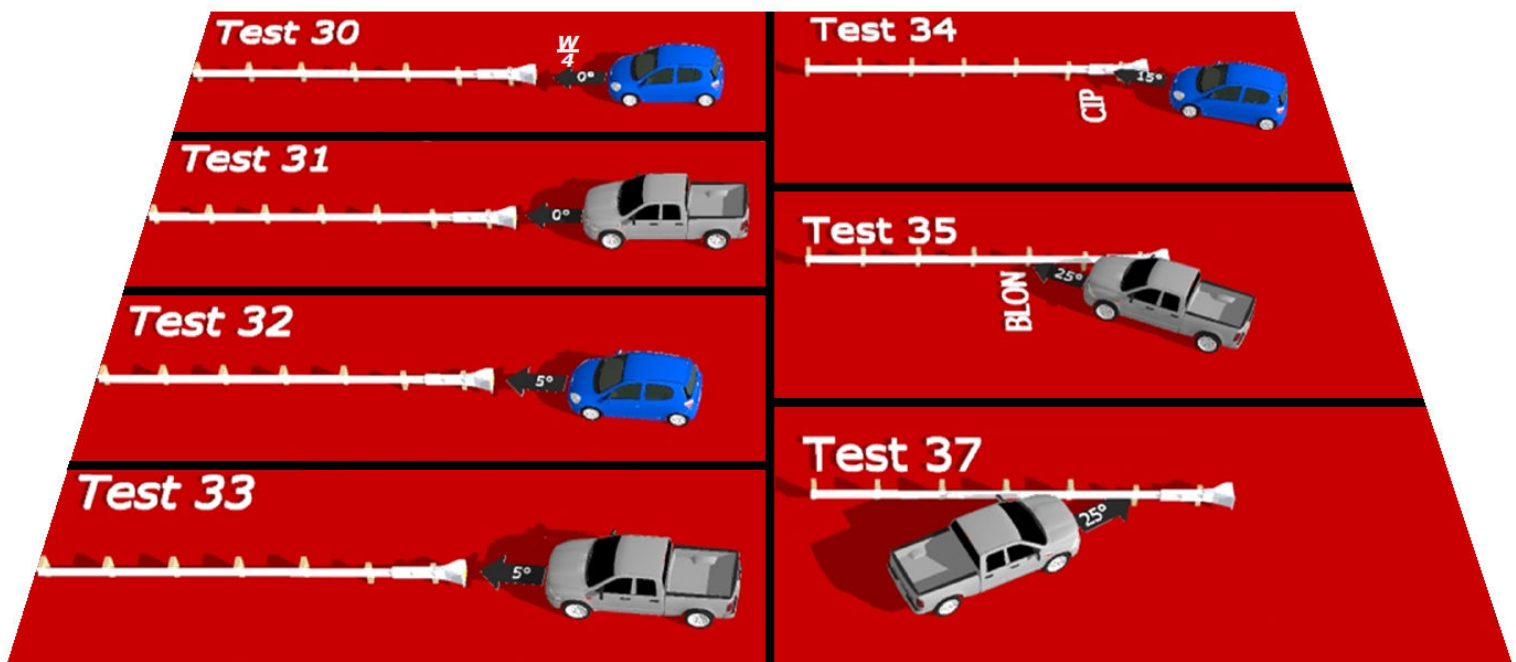

Figure 1: MASH End Terminal Crash Test Evaluation

4.0 Set-out

4.1 Site Grading Requirements

Grading around the area of a guardrail end terminal is an important consideration regardless of the specific terminal selected. The site grading should be considered from three perspectives; advance grading, adjacent grading and run-out grading. Refer to Figure 4.

4.1.1 Advance Grading

It is recommended that the area in advance of a terminal be limited to a grading of 10H:1V to ensure that the vehicle's suspension is neither extended nor compressed at the moment of impact.

4.1.2 Adjacent Grading

Adjacent grading refers to the surface on which the terminal is installed and the area immediately behind. It is recommended that this area be relatively flat (10H:1V) so that the terrain does not contribute to vehicle behaviour. Where re-direction is expected (beyond the point-of-need), the terminal posts should have 600mm of fill material behind them, providing sufficient lateral support.

For near head-on impacts with the front-right of a vehicle, grading of 10H:1V should extend 1500mm behind the nose of the terminal, minimising the potential for vehicle roll as the terminal is engaged.

4.1.3 Run-Out Grading

Since all w-beam guardrail end terminals are gating, consideration should be given to the area parallel to and behind the safety barrier system. When struck at or near the nose at an angle, w-beam guardrail end terminals will typically yield, allowing a vehicle to continue into the area immediately behind and beyond the terminal.

The Austroads Guide to Road Design – Part 6 nominates an area measuring 18m long x 6m wide measured from the nose of the terminal to be reasonably traversable and free from fixed object hazards. This may be difficult to address, particularly on existing roadways. If a clear run-out area is not possible, this area should at least be similar in character to adjacent unshielded roadside areas.

Generally a risk evaluation would conclude that an end terminal installed without the required run-out area could be considered a lower risk than leaving a roadside hazard completely unshielded.

4.2 The Point-of-Need

This is the location along the terminal that has demonstrated complete containment and re-direction. When assessed for MASH TL3 conditions, this impact is performed with a 2,270kg pick-up truck travelling at 100km/h and impacting at 25°.

The MSKT point-of-need is post location 3, a distance of 3.81m downstream from the start of the terminal.

In order to adequately shield a roadside hazard, the beginning length-of-need is required to be calculated for that site. At a minimum, the MSKT should be installed so that the terminal point-of-need (post 3) aligns with the site beginning-length-of-need. Figure 6 provides an example.

The point-of-need location may vary between terminal types. However, provided the terminal point-of-need and the site beginning-length-of-need are aligned, the road safety barrier system will provide the same re-directive capabilities, regardless of the terminal selected.

4.3 Kerbs

Placing kerbs in front of w-beam guardrail terminals on high-speed roads is not recommended. As an alternative, a shallow gutter in front of the terminal or subsurface grated drainage should be considered.

On lower speed roads that often require a kerb, it is recommended that the location of the kerb be as close as practicable to the face of rail minimising the potential for vehicle launching. If the posted speed is $\geq 80\text{km/h}$ the kerb height should be limited to 100mm.

4.4 Placement in Concrete

The line posts of the MSKT provide lateral resistance during side-on impacts and are designed to absorb some crash energy through post rotation in the surrounding material prior to fully yielding.

There may be instances when designers prefer the area beneath the safety barrier system to be paved. Whilst a paved surface has aesthetic appeal, it is important that it does not have an adverse effect on the functionality of the terminal.

When installed in a paved area, it is recommended that a 'leave-out' area in the pavement be provided that will allow at least 180mm of post deflection at ground line. This 'leave-out' area can be filled with a low-strength concrete mix. Refer to Figure 7.

4.5 Other Obstructions & Hazards

During head-on impacts, the MSKT impact head slides over the w-beam guardrail. It is important that there are no obstructions located or positioned below the impact head, such as vegetation, that may hinder the travel of the impact head.

Since the MSKT functions by sequentially kinking the rail away from the traffic face, a risk assessment is

recommended if pedestrians and/or cyclists will be accessing the area behind the terminal.

4.6 Use of an Offset

The MSKT is classified as a tangential end terminal and is installed parallel to the roadway. However, the MSKT may be installed on a 25:1 straight flare away from the roadway. This will achieve a 600mm offset measured from the face of rail over the length of the TL3 configuration.

Whilst providing a straight flare is not mandatory, the use of a straight flare positions the impact head further away from the edge of the travelled way and reduces the potential for nuisance impacts.

4.7 Placement on Curves

When the MSKT is installed at the end of a guardrail system following a curved alignment, the MSKT must be installed along a straight alignment (using straight rails) over the length of the terminal. To prevent encroachment onto the travelled way, the terminal may be installed on a straight flare as previously described.

4.8 Length Between Terminals

The recommended minimum length of a w-beam guardrail barrier is generally 30m (includes the length of the terminals), although this may vary depending upon the design speed. There is no limitation on maximum length of a w-beam guardrail barrier.

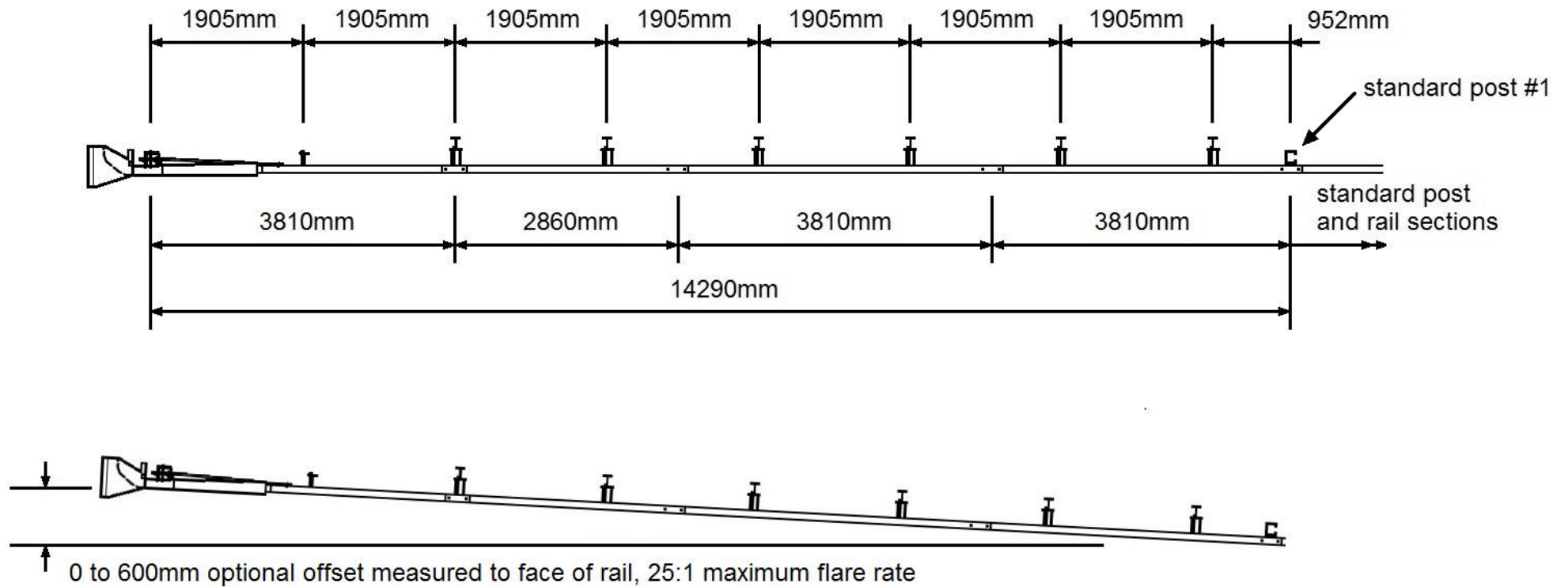
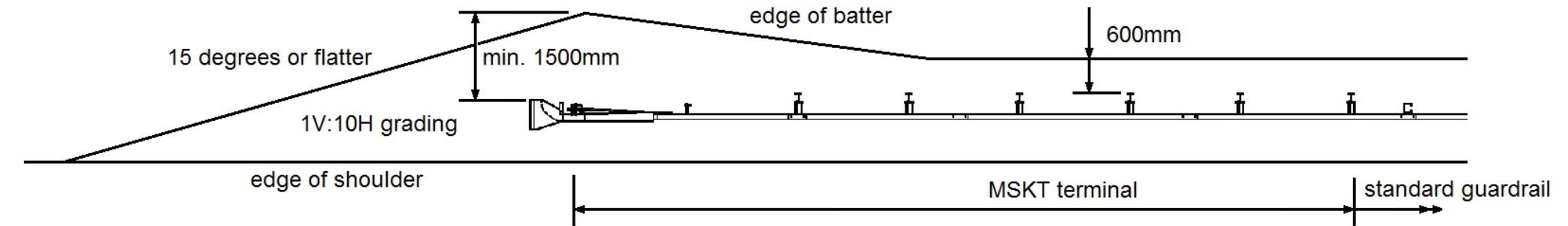
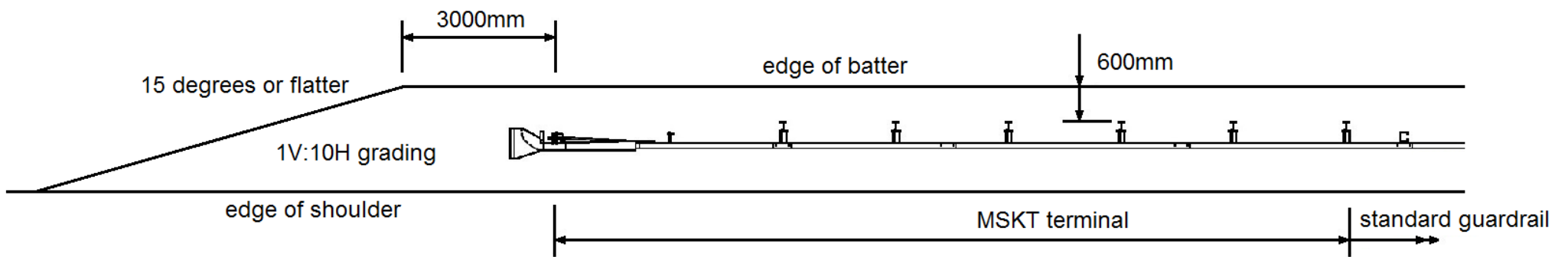

Figure 3: MSKT Set-Out (TL3)



Preferred Option



Alternate Option

Figure 4: MSKT Grading Arrangement

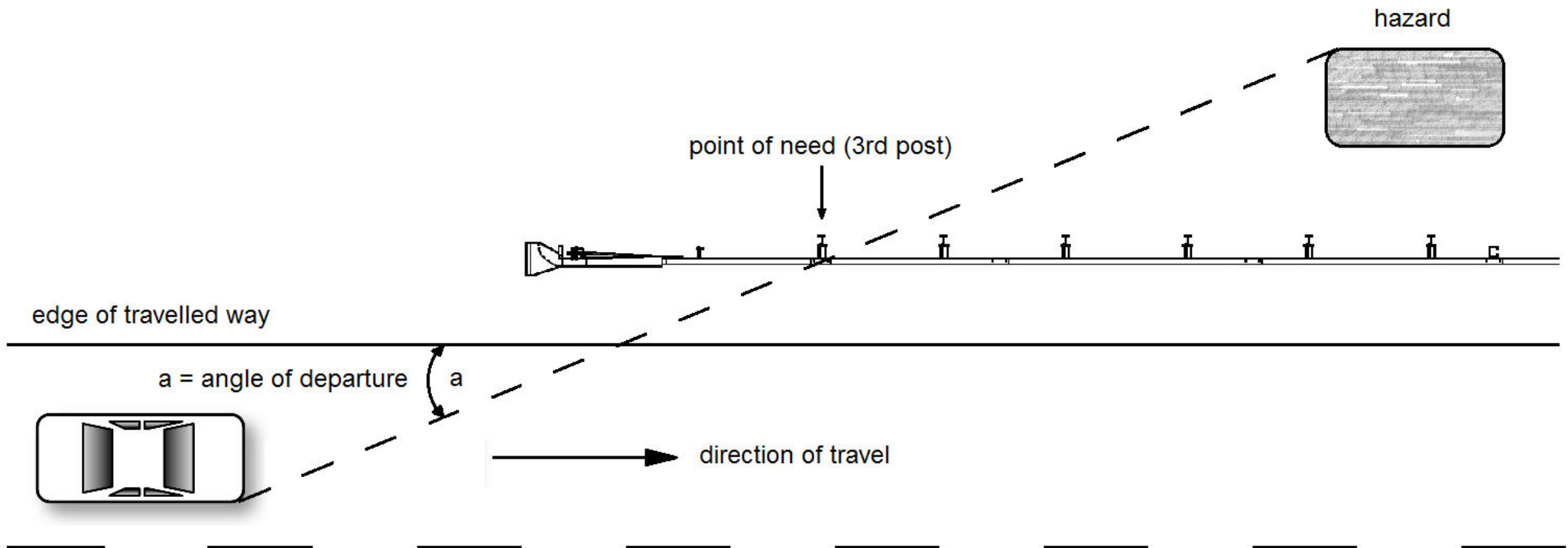

Figure 5: Point-of-Need Set-Out

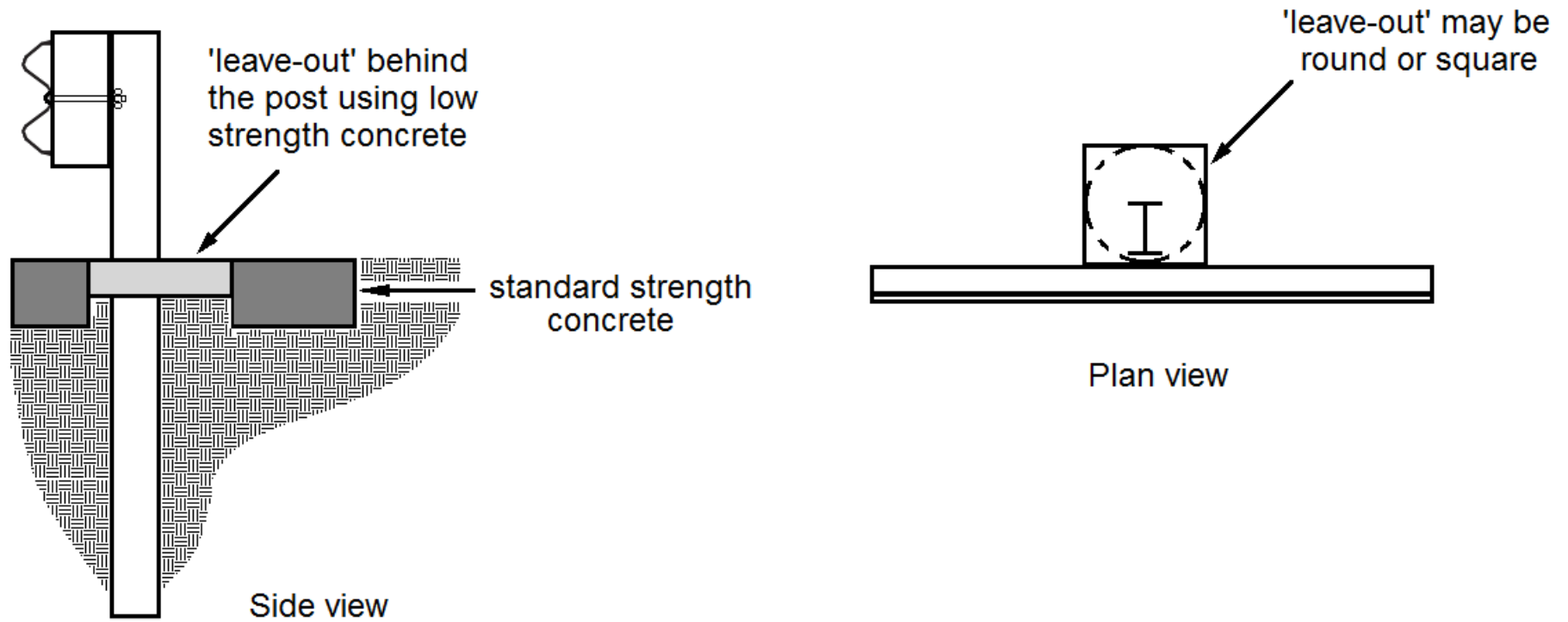
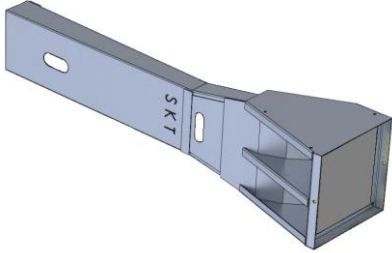

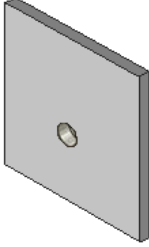

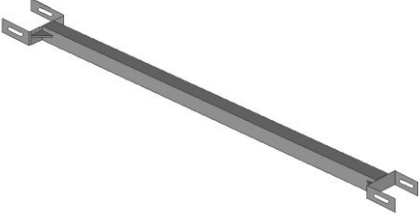

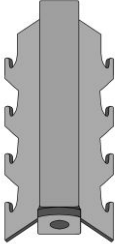
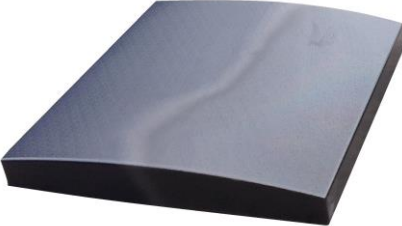
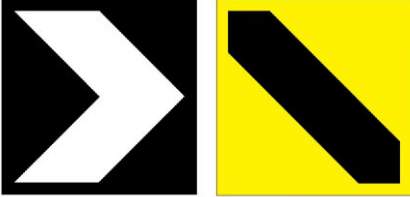

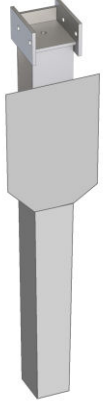

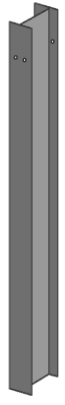
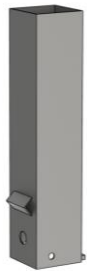
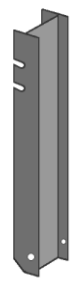

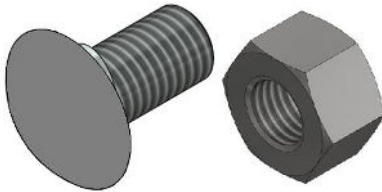

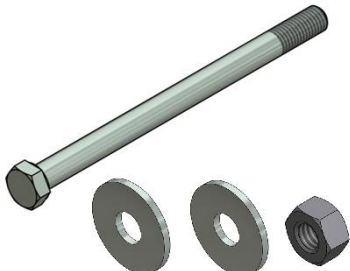
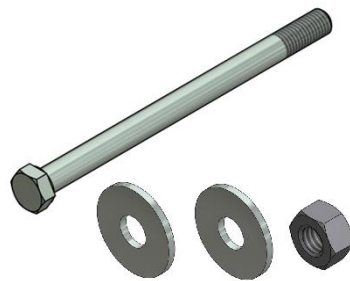
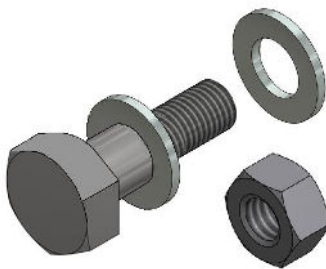

Figure 6 : Post in Concrete Pavement

5.0 Bill of Materials

Item Description	Item Quantity		Unit Weight (kg)
	TL2 Configuration	TL3 Configuration	
MSKT Impact Head	1	1	80
3810mm Slotted Anchor Rail	1	1	43
2860mm Mid-Span W-Beam Rail	2	1	32
3810mm Mid-Span W-Beam Rail		2	43
150 x 150mm RHS Hinged Post Top – Post 1	1	1	11
Hinged Post Bottom w/ Soil Plate – Post 1	1	1	55
Hinged Post Top – Post 2	1	1	11
Hinged Post Bottom – Post 2	1	1	18
1830mm Steel Line Post	3	6	24
200mm Wide Blocking Piece	3	6	4
2m Anchor Cable with 2 x 1" Nut/Washer	1	1	7
Anchor Bracket	1	1	6
Bearing Plate	1	1	5
Bearing Plate Retainer Tie	1	1	
M16 x 220mm Hex. Bolt/Nut/2 Washers	2	2	
M20 x 220mm Hex. Bolt/Nut/2 Washers	1	1	
1/2" x 1 1/4" Anchor Bracket Shoulder Bolt/Nut/2 Washers	8	8	
M8 x 25mm Hex. Bolt/Nut/2 Washers	2	2	
5/8" x 10" Mushroom Post Bolt/Nut	3	6	
M16 x 32mm Mushroom Splice Bolt/Nut	25	33	
Total Weight	390 kg	550 kg	

6.0 Component Identification (not to scale)

		
<p>Impact Head</p>	<p>3810mm Slotted Anchor Rail</p>	
		
<p>Bearing Plate</p>	<p>2860mm & 3810mm Mid Span Rails</p>	
		
<p>Ground Strut</p>	<p>2m Anchor Cable with Nuts/Washers</p>	
		
<p>Cable Anchor Bracket</p>	<p>Impact Head Cover (optional)</p>	<p>Impact Head Delineator Options</p>

		
Bottom Post 1	Bottom Post 2	Steel Line Post
		
Top Post 1	Top Post 2	200mm Blocking Piece
		
M16 x 32mm Splice Bolt & Nut	5/8" x 10" Post Bolt/Nut	M20 x 220mm Bolt/Nut/Washers
		
M16 x 220mm Bolt/Nut/Washers	1/2" Anchor Bracket Shoulder Bolts	M8 x 25mm Bolt/Nut/Washers

7.0 Tools Required

Tools required for the installation of the MSKT are the same as those used for the installation of standard guardrail. This includes;

- Post driving equipment or auger;
- Hand tamper;
- Impact driver drill with attachments;
- Metal snips;
- String line;
- Tape measure;
- Hammer;
- 12mm diameter pinch bar; and
- Slings or chains.

7.1 Recommended PPE

It is recommended that the following personal protective equipment (PPE) be provided for the safe installation of the MSKT;

- Safety footwear;
- Gloves;
- Hearing protection;
- High visibility clothing;
- Sun protection (broad brimmed hat, sunscreen & tinted safety glasses); and
- PPE as required for the use of post driving equipment or auger.

8.0 Site Establishment

8.1 Traffic Control

Prior to the commencement of any work, the site should be evaluated for risks to workers, pedestrians and other road users. The establishment of traffic control should provide safe travel for passing vehicles and/or pedestrians and appropriately protect workers near the roadside.

8.2 Underground Services

The installation of the MSKT requires the supporting posts to be embedded into the ground. Prior to the installation of posts an investigation for potential underground hazards is recommended.

8.3 Overhead Obstructions

The site should be evaluated for potential overhead obstructions that may present a risk during the installation process. These obstructions typically include power lines, signage or trees.

8.4 Unloading Exclusion Zone

Only appropriate load-rated slings and chains should be used for the safe unloading of product. It is recommended that an exclusion zone be maintained around the unloading process. This provides distance between moving machinery and workers in the event that goods or the machinery move unexpectedly.

Unloading and the storing of the product on a level surface is recommended. Storing product adjacent to the installation area eliminates the requirement for workers to carry items over long distances.

9.0 Installation Sequence

The major steps in the installation of the MSKT are as follows;

- Set-out;
- Installing the bolted hinged posts at post locations 1 and 2;
- Installing the ground strut;
- Installing the steel line posts at post locations 3 and beyond;
- Attachment of the cable anchor bracket using the special shoulder bolts;
- Attachment of the guardrail;
- Attachment of the impact head; and
- Attachment of the cable assembly.

9.1 Set-Out

It is recommended that a string line be used to establish the alignment of the terminal and the post locations. The offsets nominated in this document are measured to the face of rail.

When establishing the post locations of the terminal, take care to note the following;

- The first two posts from the end of each terminal have no offset blocking piece;
- The 200mm blocking pieces used within the terminals are wider than the standard w-beam blocking pieces;
- The 1.905m spacing for the posts throughout the terminal is different from the standard w-beam barrier spacing of 2.0m; and
- With the exception of the 1st anchor rail, the intermediate rail panels are spliced mid-span between posts;
- The installed rail height is 790mm; and

The MSKT is a tangential terminal and no offset is required. However, if space permits the use of a 25:1 or flatter straight flare may be used to reduce the potential for nuisance impacts with the terminal.

When installing a TL3 SKT-SP the maximum offset is 600mm.

9.2 Installation of Hinged Posts 1 & 2

Potential Hazards: Use of post driving equipment or auger, contact with underground hazards, excessive noise, hand injury from pinch points and injury from movements and posture.

Recommended Control Measures: Observe the safe work instructions as per machinery requirements, ensure the area has been inspected for underground hazards, wear appropriate hearing protection, wear gloves, observe correct techniques when lifting (bend at the knees), and use a team lift when installing bottom post 1.

Hinged posts are installed at post locations 1 and 2. The hinged post assembly comprises a bottom section and top section that is bolted together. The lower section of the post must be installed prior to the attachment of the upper section.

The bottom of post 1 is aligned so that the soil plate is located on the downstream side of the post i.e. away from the impact head.

The bottom of post 1 may be installed by;

- Driving with an appropriate driving head to the required depth, approximately 1800mm, or
- Auguring a pilot hole approximately 1800mm deep, and driving the post to the required depth with an appropriate driving head, or
- Auguring a hole approximately 1800mm deep, placing the post in the hole and backfilling. The post hole should be large enough (e.g. 300mm diameter) to allow the backfill material to be placed in 150mm lifts and compacted with tamping equipment.

The bottom of post 2 is aligned so that the hinge bolt hole is located on the downstream side of the post i.e. away from the impact head.

Post 2 is positioned 1.905m from post 1.

The bottom of post 2 may be installed by;

- Driving with an appropriate driving head to the required depth, approximately 1800mm, or
- Auguring a pilot hole approximately 1800mm deep, and driving the post to the required depth with an appropriate driving head, or
- Auguring a hole approximately 1800mm deep, placing the post in the hole and backfilling. The post hole should be large enough (e.g. 300mm diameter) to allow the backfill material to be placed in 150mm lifts and compacted with tamping equipment.

Once installed, bottom posts 1 & 2 should not protrude more than 100mm above ground level.

Note: If installing bottom posts 1 & 2 with a driving head, do not pound on the side plates as this may cause damage to the welds.

The top for post 1 is a 150mm x 150mm rectangular hollow section (RHS). Top post 1 is orientated with the angle spacer facing oncoming traffic. The bearing plate will ultimately rest on the angle spacer of top post 1.

The side plates of bottom post 1 are fabricated with two (2) holes.

A M16 x 220mm hex. bolt, nut and two (2) washers is used to secure the top and bottom post sections through the upstream hole of bottom post 1 (nearest the impact head).

The downstream hole of bottom post 1 is used to secure the ground strut.

Position the ground strut between posts 1 and 2 and secure to post 1 through the downstream hole with a M16 x 220mm hex. bolt, nut and two (2) washers.

The top for post 2 is an I-beam cross section. The upper portion of post 2 features two open slots used to attach the guardrail to the post. The open slots are orientated towards post 1 (nearest the impact head).

A M20 x 220mm hex. bolt, nut and two (2) washers is used to secure bottom post 2, top post 2 and the ground strut. Once secured the bolt should be on the downstream end of the post (towards post 3).

There is no torque requirement for these bolts. They should be tightened to a snug position.

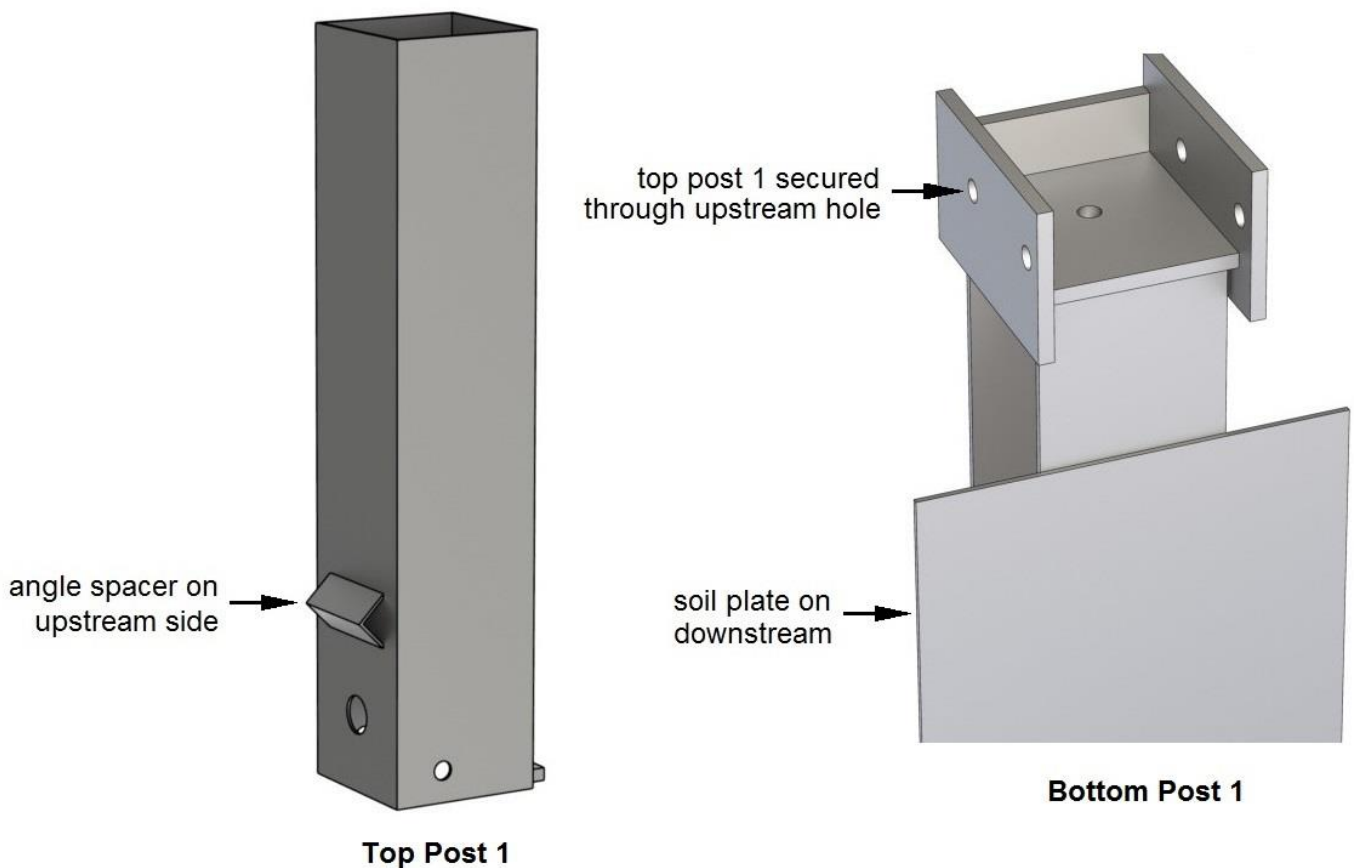

Figure 7: Post 1 Identification

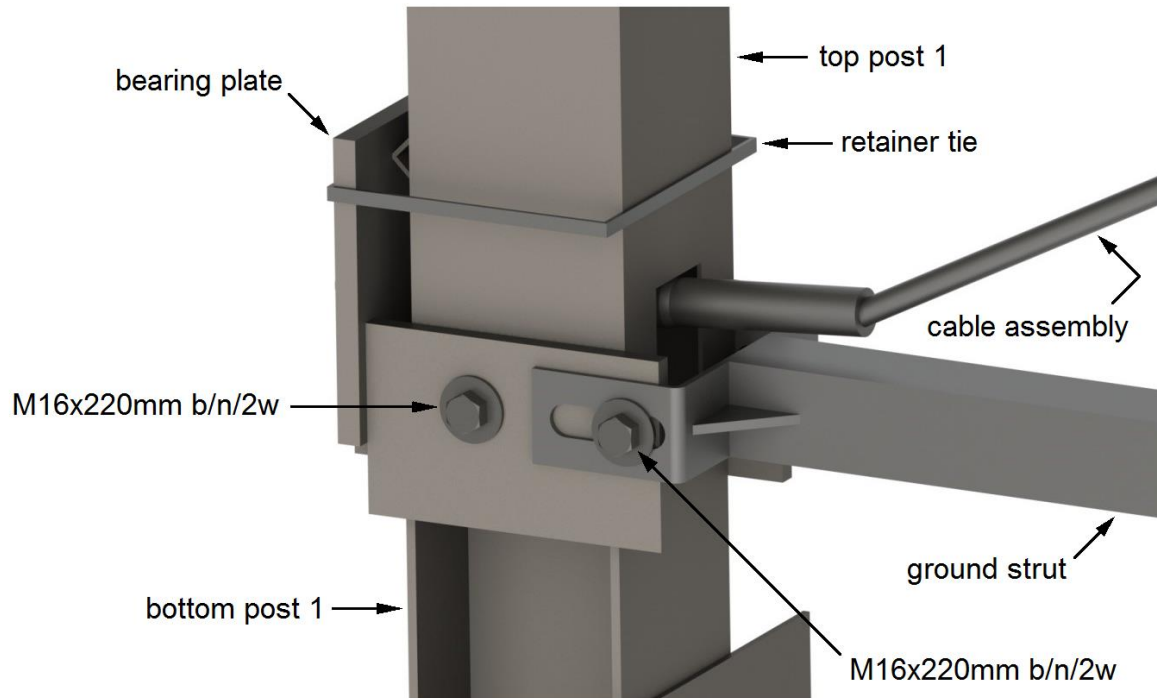
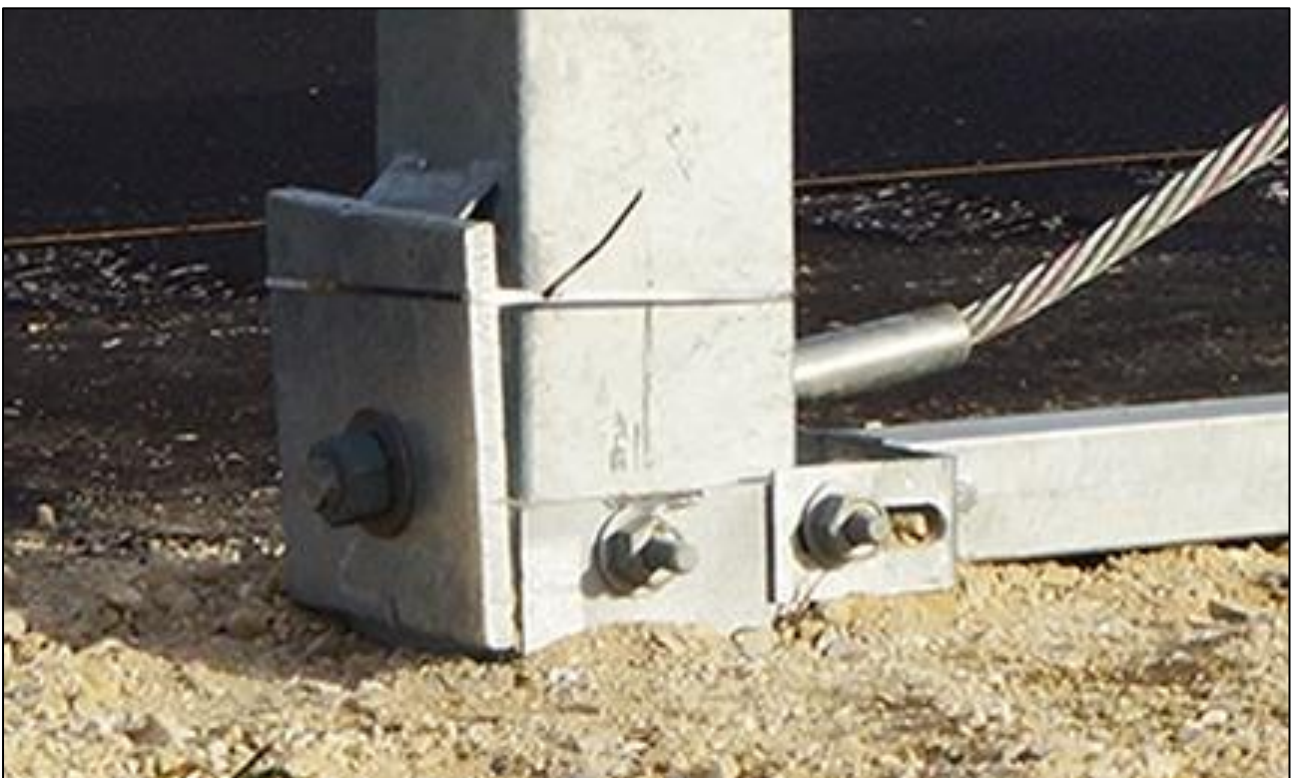

Figure 8: Post 1 Connection Detail



Post 1 Connection Detail

9.3 Installation of Steel Line Posts

Potential Hazards: Use of post driving equipment or auger, contact with underground hazards, excessive noise and hand injury from pinch points.

Recommended Control Measures: Observe the safe work instructions as per machinery requirements, ensure the area has been inspected for underground hazards, wear appropriate hearing protection and wear gloves.

The steel line posts are approximately 1830mm in length and are manufactured from an I-beam cross section. They are installed as post locations as follows;

TL2 MSKT: Post locations 3 to 5.

TL3 MSKT: Post locations 3 to 8.

The steel line posts may be installed by;

- Driving with an appropriate driving head to the required depth, approximately 1100mm, or
- Auguring a pilot hole approximately 1100mm deep, and driving the post to the required depth with an appropriate driving head, or
- Auguring a hole approximately 1100mm deep, placing the post in the hole and backfilling. The post hole should be large enough (e.g. 300mm diameter) to allow the backfill material to be placed in 150mm lifts and compacted with tampering equipment.

The steel line posts are spaced at 1905mm centres.

9.4 Attaching the Cable Anchor Bracket

Potential Hazards: Hand injury from pinch points.

Recommended Control Measures: Wear gloves.

For ease of installation, it is recommended that the cable anchor bracket be secured to the slotted anchor rail prior to securing the rail to the posts. This ensures that the top of post 2 does not interfere with the attachment of the cable anchor bracket.

The anchor rail is identified by the horizontal slots punched into the end of the rail. The anchor rail also has eight 19mm diameter holes to accommodate attachment of the cable anchor bracket.

The cable anchor bracket is secured with eight (8) 1/2" x 1 1/4" hex. shoulder bolt, nut and (2) washers. A single washer is positioned on either side of the rail.

Note: The cable anchor bracket bolts and nuts are specially engineered. No other bolts are to be used at this location. The bolts are manufactured with a unique shoulder.

The cable anchor bracket is positioned with the welded plate of the bracket towards post location 2. Align the bracket with the holes in the anchor rail and insert the bolts and hand-tighten.

Once all bolts are inserted, ensure the shoulders align with the cable bracket slots. When positioned, slightly tap with a hammer until the shoulders and slots are fully engaged. The bolts can now be fully tightened. There is no torque requirement for these bolts. They should be tightened to a snug position.

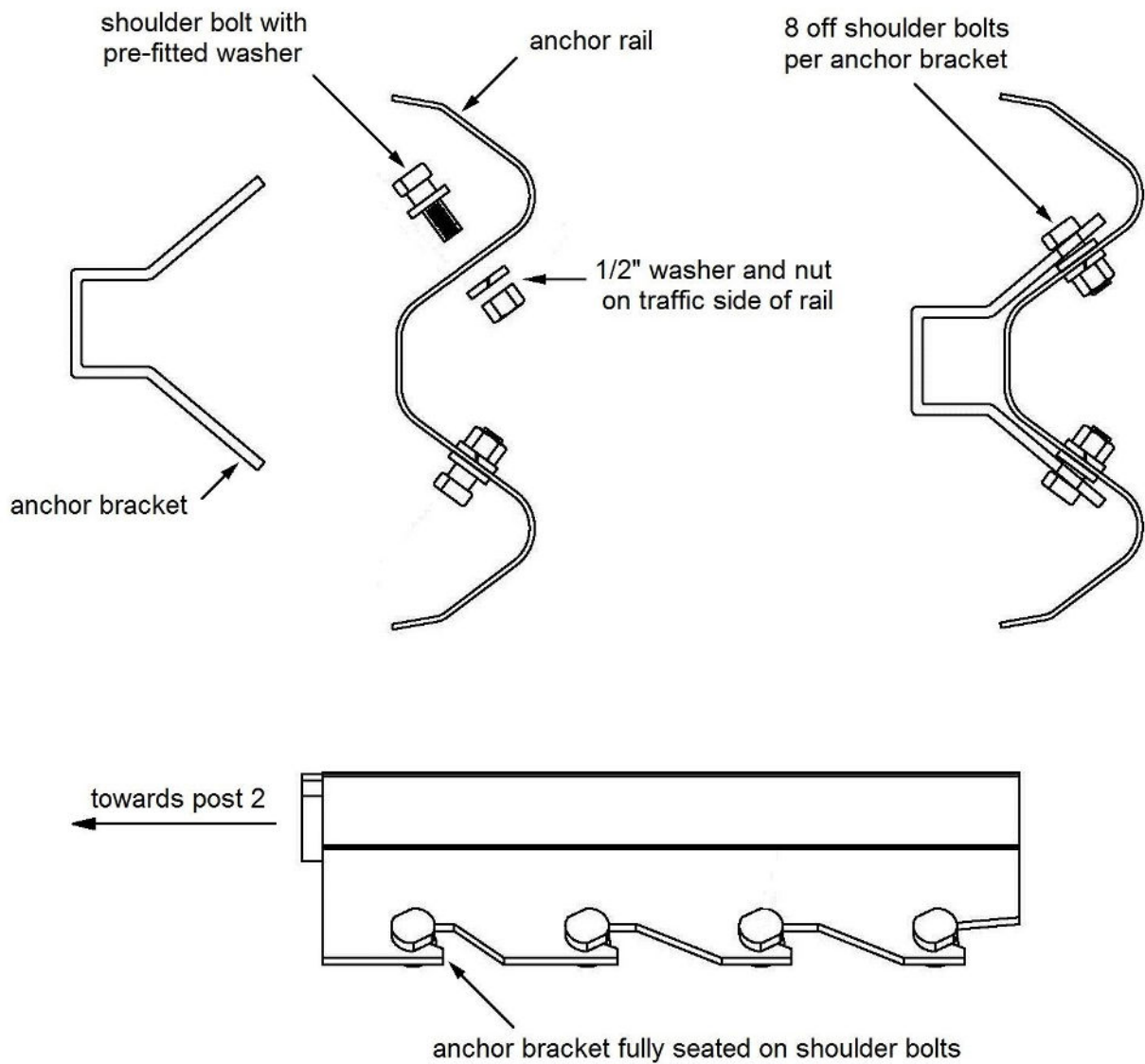

Figure 9: Attachment of Cable Anchor Bracket

9.5 Attaching the Rails & Blocks

Potential Hazards: Injury from movements and posture, hand injury from pinch points, strain to wrists from tightening bolts and excessive noise from use of impact driver.

Recommended Control Measures: Observe correct techniques when lifting rails (bend at the knees), wear gloves, use a pinch bar to align holes, use an impact drill to tighten bolts and wear appropriate hearing protection.

The anchor rail is positioned at the start of the terminal with the slots towards post 1. The anchor rail is secured to post 2, using a standard M16 x 32mm mushroom head splice bolt and nut. The top post is fabricated with two post slots. The use of the top slot will correctly position the anchor rail at 790mm above ground level.

Note: The anchor rail is not bolted at post 1.

Subsequent rails position the splice connection mid-span between posts.

Note: The TL3 MSKT requires one (1) 2860mm and two (2) 3810mm rails following the anchor rail. The TL2 MSKT requires two (2) 2860mm rails following the anchor rail.

All rails are spliced together using eight (8) standard M16 x 32mm mushroom head bolts and nuts. The rail lap is orientated so that the leading edge of the splice is shielded from the nearside approaching traffic.

The use of a pinch bar will assist in aligning the splice holes as the bolts are inserted. The use of a driving pin to elongate the splice holes is NOT permitted.

At the steel line post locations a 200mm wide blocking piece is positioned between the posts and the rail. The rails are then secured with a 5/8" x 10" mushroom head bolt and nut with the bolt passing through the rail, blocking piece and post.

There is no torque requirement for these bolts. They should be tightened to a snug position

The finishing height of the rail is 790mm ± 20mm above ground level.

Note: All rails used within the MSKT are straight. No curved rails are permitted within the terminal section.

9.6 Attaching the Impact Head

Potential Hazards: Injury from movements and posture and hand injury from pinch points.

Recommended Control Measures: Observe correct techniques when lifting the impact head (bend at the knees), use a team lift, wear gloves and use a pinch bar to align impact head.

Ensure the cable anchor bracket is secured to the anchor rail prior to the attachment of the impact head. Align the impact head over the end of the anchor rail with the protruding tube positioned on the non-traffic side of the system. Slide the impact head forward until the post angle attachments on the impact head are aligned with the holes in post 1.

When correctly installed, the exit slot of the MSKT impact head is towards the non-traffic side of the system.

Secure the impact head to post 1 with two (2) M8 x 25mm hex. bolt, nut and (2) washers.

9.7 Installing the Cable Assembly

Potential Hazards: *Hand injury from pinch points.*

Recommended Control Measures: *Wear gloves.*

The cable assembly is integral to the anchorage of the terminal, contributing to the tensile and flexural strength of the system.

Place the cable assembly through the cable anchor bracket and through the opening at the base of post 1. Secure the cable assembly to the anchor bracket with the 1" hex. nut and washer that is supplied pre-attached to the cable.

Place the bearing plate at the base of post 1 with the 125mm dimension up and the 75mm down. The bearing plate will rest on the angle spacer welded to post 1. Secure the cable assembly to the bearing plate with the 1" hex. nut and washer that is supplied pre-attached to the cable.

To prevent rotation of the bearing plate, secure with a cable tie positioned around the post.

While tightening the cable, use a hammer to tap the cable anchor bracket from the downstream end to ensure that it is securely interlocked with the shoulder bolts. Restrain the cable at the end being tightened with vice grips to avoid twisting the cable.

Upon completion of installation, the cable should be taut.

9.8 Installation of Impact Head Cover

The installation of impact head covers is a requirement on the Victorian classified road network. The attachment of an impact head cover is optional outside of Victoria. This will be at the discretion of the project manager.

The covers slide over the impact head and is secured at the sides using galvanised self-drilling metal screws.

9.9 Attachment of Delineation.

The style of delineation is dependent upon state road authority requirements. The delineator is an adhesive marker that attaches directly to the impact head. If a cover is to be installed, the delineation will attach to the impact head cover.

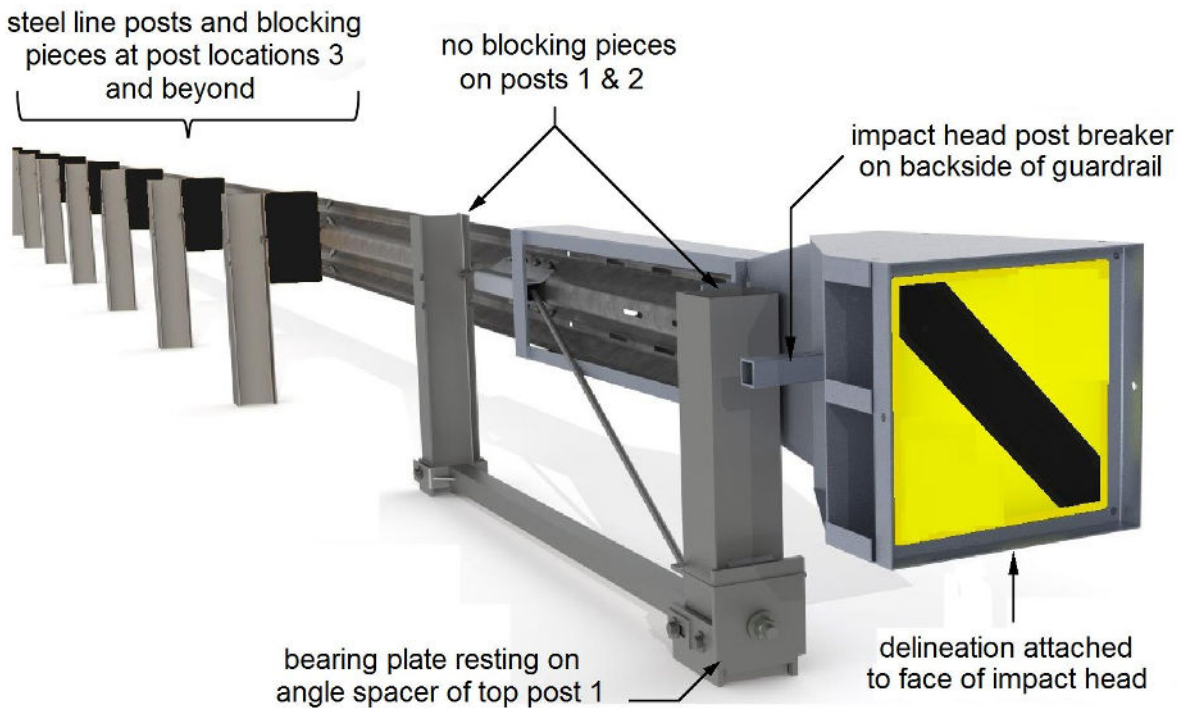
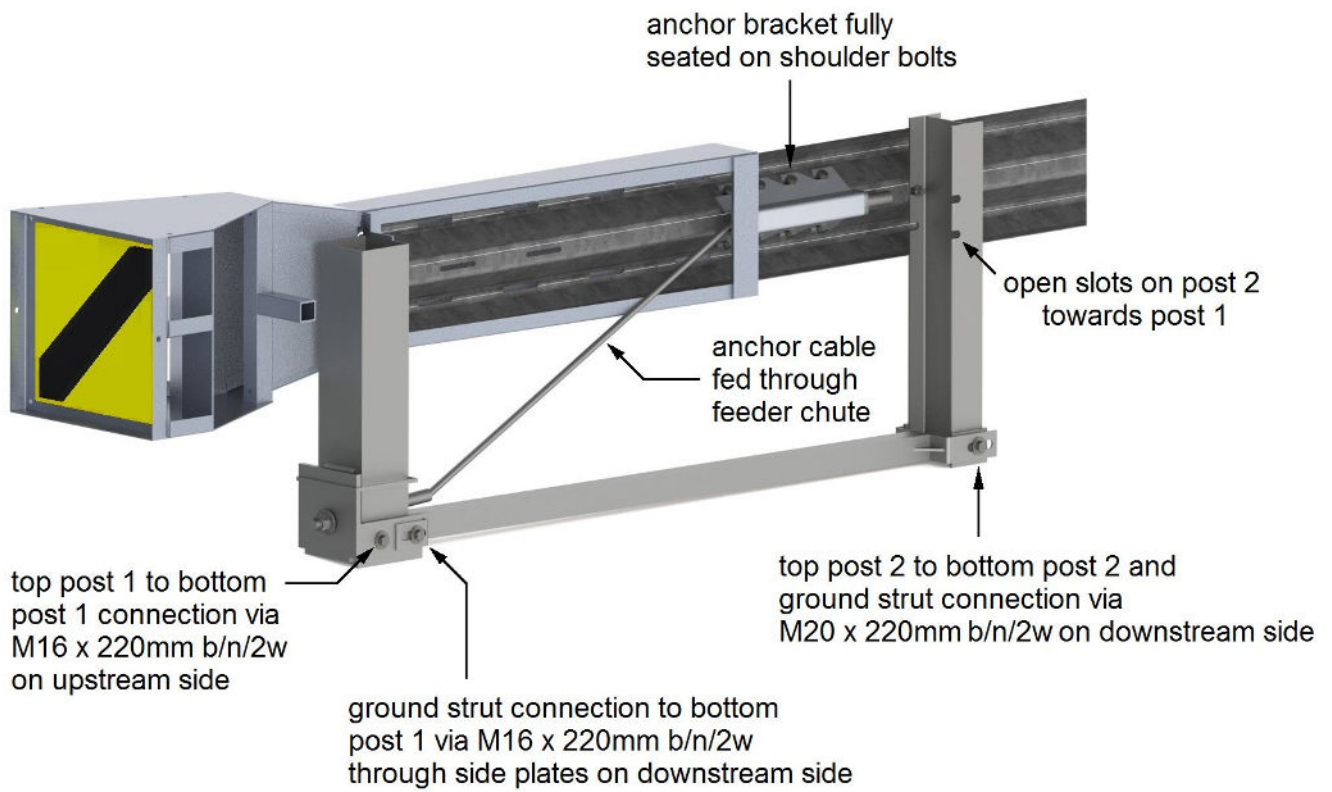
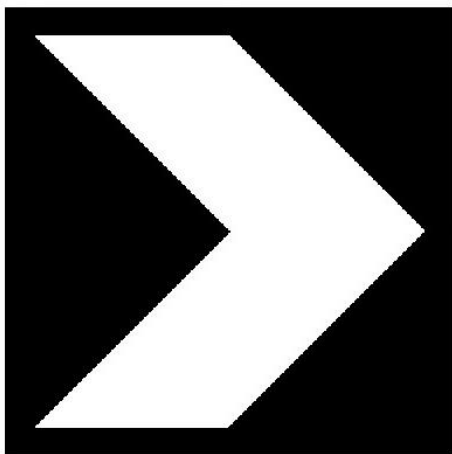
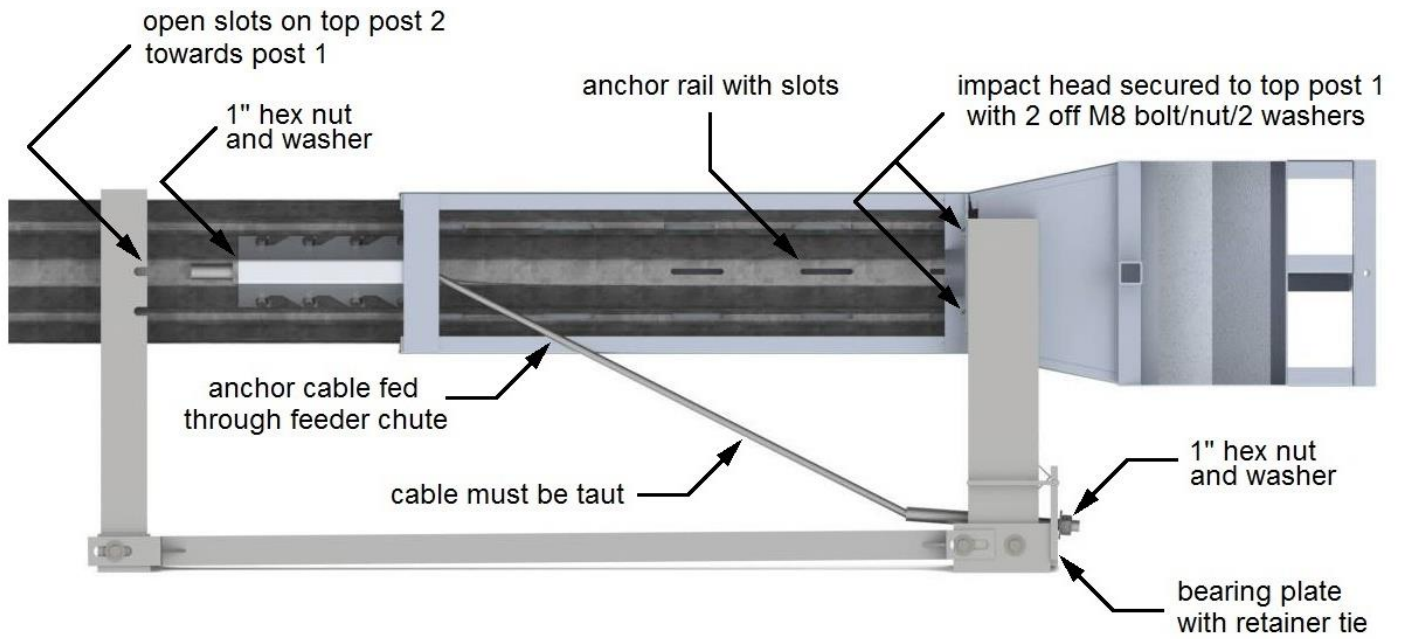
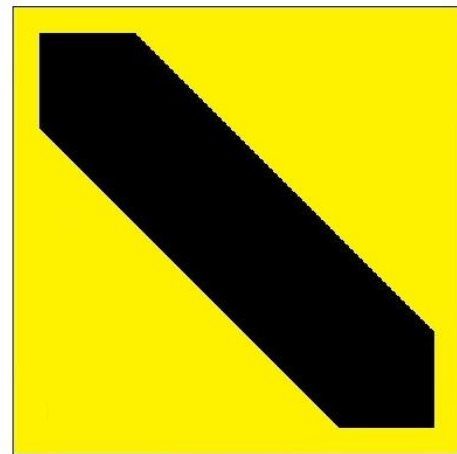

Figure 10: Cable Assembly and Impact Head Assembly Detail



reflective yellow on black



black on reflective yellow

Figure 11: MSKT Side View & Impact Head Delineation Options



Impact Head with Cover



Steel Line Post with 200mm Blocking Piece at Post Location 3



MSKT Installation Checklist

Project Reference: _____

Location: _____

Inspected By: _____ Date: _____

<input type="checkbox"/>	The height measured to the top of the terminal rails is 790mm ± 20mm.
<input type="checkbox"/>	The rails throughout the terminal are straight and not curved.
<input type="checkbox"/>	The 1 st rail is the 3810mm anchor rail containing horizontal slots.
<input type="checkbox"/>	The anchor rail is not secured to post 1.
<input type="checkbox"/>	The anchor rail is secured to post 2 with a M16 x 32mm mushroom head bolt & nut.
<input type="checkbox"/>	The anchor rail is spliced at post 3 with subsequent terminal rails spliced mid-span between posts.
<input type="checkbox"/>	All rails are spliced with eight (8) M16 x 32mm mushroom head bolt & nuts.
<input type="checkbox"/>	The rail lap is orientated so that the leading edge of the splice is shielded from approaching traffic.
<input type="checkbox"/>	Hinged post 1 is bolted on the upstream side of the post with a M16 x 220mm bolt/nut & 2 washers.
<input type="checkbox"/>	Hinged post 2 is bolted on the downstream side of the post with a M20 x 220mm bolt/nut & 2 washers.
<input type="checkbox"/>	Bottom posts 1 and 2 do not protrude more than 100mm above the ground line.
<input type="checkbox"/>	Top post 2 is orientated with the open slot to receive the post bolt on the upstream side of the post.
<input type="checkbox"/>	The posts throughout the terminal section are spaced at 1905mm centres.
<input type="checkbox"/>	200mm blocking pieces are attached to the steel line posts at post locations 3 and beyond.
<input type="checkbox"/>	The rail is secured to the steel line posts with a 5/8" x 10" mushroom head bolt & nut.
<input type="checkbox"/>	The protruding tube on the impact head is positioned on the non-traffic side of the system.
<input type="checkbox"/>	The impact head is secured to post 1 with two (2) M8 x 25mm bolt/nut & 2 washers.
<input type="checkbox"/>	The bearing plate at post 1 is correctly aligned with the 125mm dimension up and the 75mm down.
<input type="checkbox"/>	The cable anchor bracket is properly secured to the anchor rail using the special shoulder bolts.
<input type="checkbox"/>	The cable assembly is taut and a retainer is fitted to the bearing plate.
<input type="checkbox"/>	A ground strut is secured between post 1 and 2 using the M16 x 220mm bolt/nut & 2 washers at post 1 and a M20 x 220mm bolt/nut & 2 washers at post 2.
<input type="checkbox"/>	All bolts are tightened.
<input type="checkbox"/>	The fill material around the posts is suitably compacted.
<input type="checkbox"/>	Any minor damage to the galvanised finish is repaired using two coats of an organic zinc rich pain.
<input type="checkbox"/>	A cover is attached to the impact head (if required).
<input type="checkbox"/>	Delineation is attached to the impact head.

10.0 Maintenance

Except for repairs due to impacts, it is recommended that an annual inspection be undertaken to assess the following;

- The impact head is appropriately delineated;
- Debris has not accumulated around the terminal which may impede the function of the terminal;
- Vegetation around the terminal is appropriately maintained;
- Nuisance impacts have not gone undetected; and
- The anchor assembly is taut and the bearing plate is correctly aligned.

10.1 Bushfire Damage

The MSKT is predominantly constructed from hot dip galvanised steel components. The performance of hot dip galvanised components when subjected to a fire depends upon numerous factors such as flame duration, flame intensity and the characteristics of the galvanised finish.

Bushfires can produce high temperatures, however exposure of roadside structures to maximum flame intensity is generally for a short duration as the fire front moves forward. The combination of the reflectivity of the galvanised surface and the heat sink provided by the mass of the steel to which the hot dip galvanising is applied has shown galvanised steel to provide excellent performance during bushfires.

If it is observed that a bushfire has caused damage to the galvanised coating it is recommended that these item(s) be replaced. If an item adjacent to a blocking piece is being replaced i.e. post or rail, it is recommended that the blocking piece is also replaced.

11.0 Repair

In the event of a vehicle impact, damage to the terminal is to be assessed in accordance with Table 1. Typically, impacts with a MSKT will require replacement of damaged sections of rail and posts. The bearing plate, cable assembly and the anchor bracket are often reusable.

Additional tools required for repair include;

- Acetylene torch to cut away damaged rail;
- Heavy duty chain to remove the impact head;
- Sledge hammer; and
- Post extractor.

Similar to the installation sequence, it is recommended that the guidelines contained in Section 8.0 be observed in the establishment of traffic control and an unloading exclusion zone in addition to investigation for underground services and overhead obstructions.

Table 1: MSKT Damage Assessment Guidelines

Type of Damage	Description of the Damage	Remedial Action
Damage to the galvanised coating on the posts.	The sum total of the damaged area does not exceed 45cm ² (0.5% of the total surface area) and no individual damaged area exceeds 40cm ² .	An organic zinc rich paint is to be applied to the repair area in two coats.
	The sum total of the damaged area exceeds 45cm ² (0.5% of the total surface area) or an individual damaged area exceeds 40cm ² .	The post is to be replaced.
Damage to the galvanised coating on the rails.	The sum total of the damaged area does not exceed 200cm ² (0.5% of the total surface area) and no individual damaged area exceeds 40cm ² .	An organic zinc rich paint is to be applied to the repair area in two coats.
	The sum total of the damaged area exceeds 200cm ² (0.5% of the total surface area) or an individual damaged area exceeds 40cm ² .	The rail is to be replaced.
Damage to the blocking pieces.	The blocking piece is cracked or chipped.	The blocking piece is to be replaced.
Damage to the posts.	The posts are bent or the welds have cracked.	The posts are to be replaced.
Damage to the impact head.	The impact head has superficial damage. Its ability to function is not compromised.	The impact head may be reused. If uncertain, replace the impact head.
	The impact head is distorted and its ability to function is compromised.	The impact head is to be replaced.
Damage to the rails.	The rail is dented, twisted or flattened.	The rail is to be replaced.
	There are nicks in any part of the rail.	
	The slots in the rail are distorted.	
Damage to bolts.	The body of the bolt is distorted.	The bolt is to be replaced.
	The thread of the bolt is damaged.	
Disturbance of material around the posts.	The material around a post is loose.	The material is to be suitably compacted.

11.1 Removal of the Impact Head

Potential Hazards: Injury from movements and posture, hand injury from pinch points, hand injury from damaged edges and injury from sudden movement as the impact head is released.

Recommended Control Measures: Observe correct techniques when lifting the impact head (bend at the knees), wear gloves and maintain an appropriate exclusion zone around the impact head until removed from the rail.

A head-on impact with the MSKT will cause the impact head to travel over the rails. The rails are sequentially kinked as they move through the impact head.

Using an acetylene torch, cut away the damaged rail near the exit chute of the impact head. In most instances, the impact head can now be removed by hand.

If the impact head is unable to be removed, attach a heavy duty chain through the opening behind the impact plate. Secure the other end of the chain to equipment capable of pulling the impact head from the rails. Ensure the downstream rail is still bolted to the supporting posts prior to applying the load.

11.2 Removal of Damaged Posts

Potential Hazards: Hand injury from pinch points, hand injury from damaged edges and injury from sudden movement as the posts are released.

Recommended Control Measures: Wear gloves and maintain an appropriate exclusion zone around the post until removed.

Posts 1 and 2 are hinged and will typically yield at ground level. Bottom sections of posts 1 and 2 are often reusable and therefore will not be required to be removed.

Damaged steel line posts should be removed using an appropriate post extractor. Once a damaged post is removed, the ground material should be suitably compacted before a replacement post is installed.

11.3 Removal of Damaged Rails

Potential Hazards: hand injury from pinch points, hand injury from damaged edges, injury from sudden movement as rails are released and excessive noise from use of impact drill.

Recommended Control Measures: Wear gloves and wear appropriate hearing protection.

Using an impact drill, remove the splice bolts at the rail connection. Rails that have twisted or bent during impact may need to be cut into manageable sections using an acetylene torch.

11.4 Emergency Procedure After Impact

In some circumstances, an assessment of the damaged terminal is undertaken to evaluate the extent of damage and determine replacement parts required. There is often a time lag before the terminal is appropriately repaired.

In these circumstances, consideration for a temporary repair is recommended. This is achieved as follows;

- Remove any damaged rail and the impact head from the roadway;
- Using an acetylene torch, cut away the damaged rail near the exit chute of the impact head.

Remove the damaged impact head by hand. If this is not possible, attach a heavy duty chain through the opening behind the impact plate. Secure the other end of the chain to equipment capable of pulling the impact head from the rails. Ensure the downstream rail is still bolted to the supporting posts prior to applying the load.

- Locate the first upright post downstream of any damaged rail and cut off the rail approximately 225mm in front of the post. If the post is at a splice location, the rail can be removed by unbolting the splice connection.
- Re-install the impact head over the rail and secure to the post through the top and bottom angle attachments.
- If the impact head is damaged and unable to be reinstated over the rail, turn down and bury the end rail as far away from the traffic as possible.
- Erect appropriate warning signs adjacent to and in advance of the damaged terminal.

The procedures are temporary only and should only be implemented until a full repair is undertaken. It is always recommended that damage to guardrail end terminals be prioritised and undertaken as soon as possible.

11.5 Retrofit using MSKT Impact Head

The MSKT represents the latest configuration for the SKT terminal that was first introduced in 1997. Earlier versions of the SKT were crash tested in accordance with NCHRP Report 350.

Changes have been made to the impact head design with the introduction of MASH which represents a significant increase in impact energy when compared to NCHRP Report 350.

The MSKT impact head has been successfully crash tested to NCHRP Report 350 and may be used as a replacement item for pre-MASH versions of the SKT, including the SKT-350 and SKT-SP.

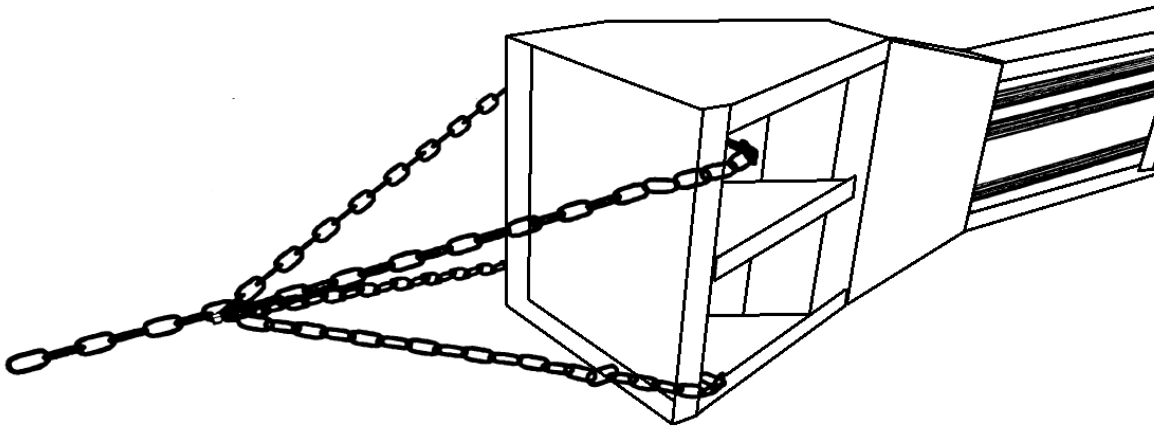
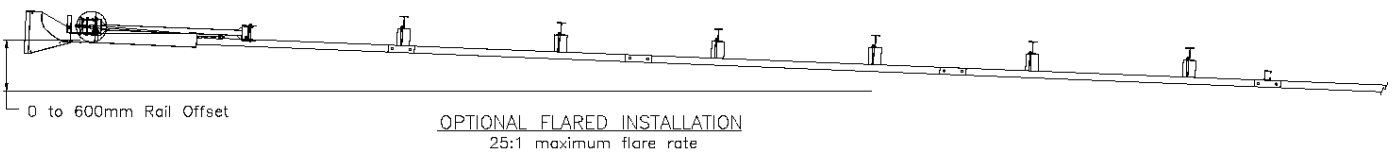
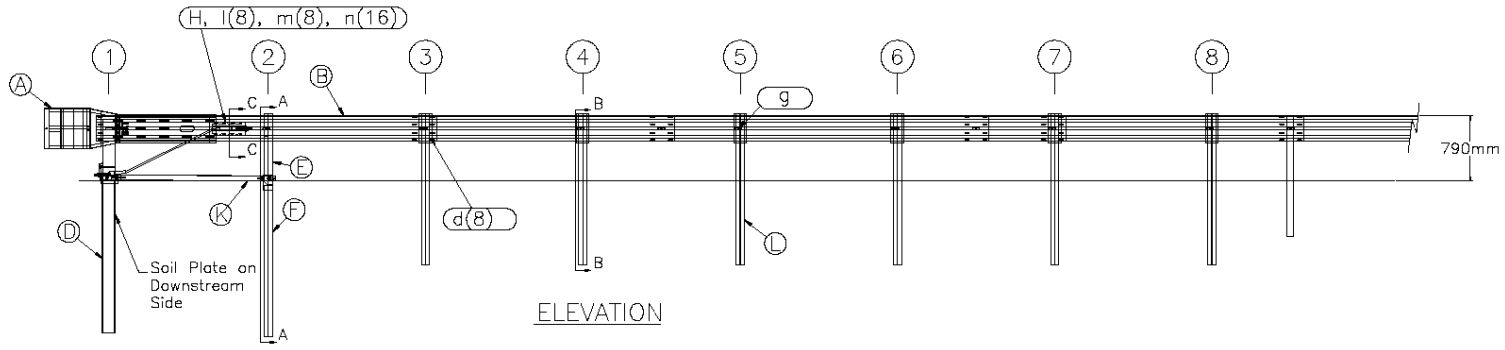
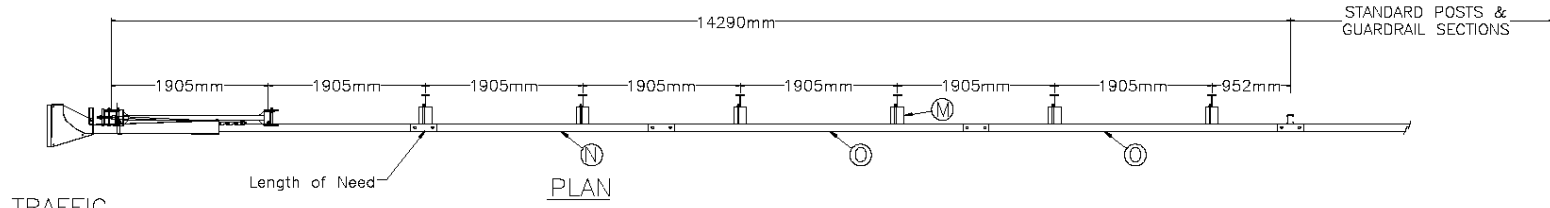

Figure 12: Attachment of Chains for Removal of Impact Head



Damaged Rail after Travelling through Impact Head



ITEM	QTY	BILL OF MATERIALS	ITEM NO.
A	1	SKT IMPACT HEAD	GE-EF-MX-3333-BG
B	1	SLOTTED ANCHOR RAIL 3810	GE-WB-SR-3810-BG
C	1	TOP POST 1	GE-PG-IS-0650-CG
D	1	BOTTOM POST 1	GE-PG-IS-1900-CG
E	1	TOP POST 2	GE-PG-IS-0860-AG
F	1	BOTTOM POST 2	GE-PG-IS-1950-AG
G	1	BEARING PLATE	GE-EF-MX-0011-AG
H	1	ANCHOR CABLE BRACKET	GE-EF-MX-0015-AG
J	1	CABLE ASSEMBLY	GE-EF-MX-2000-AG
K	1	GROUND STRUT	GE-EF-MX-4020-BG
L	6	STEEL LINE POST	GE-PG-IS-1830-CG
M	6	COMPOSITE BLOCK	GE-BL-S5-0310-AS
N	1	W-BEAM GUARDRAIL 2860mm	GE-WB-SR-2860-AG
O	2	W-BEAM GUARDRAIL 3810mm	GE-WB-SR-3810-CG

HARDWARE			
a	2	M8 x 25mm HEX BOLT	GE-FS-08-0025-HG
b	4	M8 WASHER	GE-FS-08-0000-AG
c	2	M8 NUT	GE-FS-08-0000-HG
d	33	M16 x 32mm SPLICE BOLT / NUT	GR-FS-16-0032-MG
e	2	M16 x 220mm BOLT / NUT	GE-FS-16-0220-HG
f	4	M16 WASHER	GE-FS-16-0000-CG
g	6	5/8" x 10" POST BOLT / NUT	GE-FS-58-0010-MG
h	1	M20 x 220mm BOLT / NUT	GE-FS-20-0220-HG
j	1	M20 WASHER	GE-FS-20-0000-BG
k	1	BEARING PLATE RETAINER TIE	GE-MX-MX-0011-AS
l	8	1/2" x 1 1/4" SHOULDER BOLT	GE-FS-12-0114-HG
m	8	1/2" SHOULDER BOLT NUT	GE-FS-12-0000-HG
n	16	1/2" SHOULDER BOLT WASHER	GE-FS-12-0000-AG

- NOTES:
1. THE LOWER SECTIONS OF POSTS 1 & 2 SHALL NOT PROTRUDE MORE THAN 100mm ABOVE GROUND.
 2. THE CABLE ASSEMBLY MUST BE TAUT.

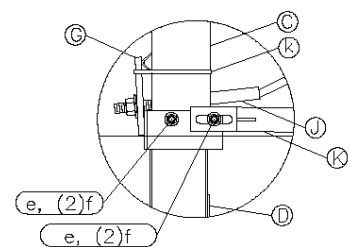

Post #1 Connection Detail

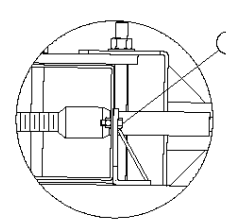

Impact Head Connection Detail

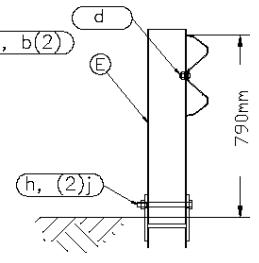

SECTION A-A
Post #2

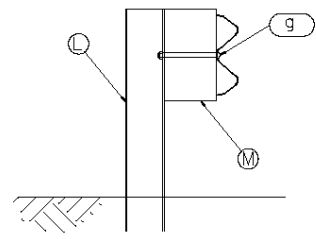

SECTION B-B
Posts #3 thru #8

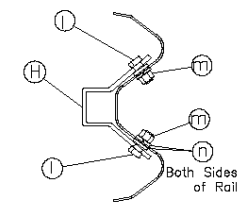

SECTION C-C
Anchor Bracket

REVISIONS				REVISIONS			
REV	DATE	DESCRIPTION	DRAWN	APPRD.	REV	DATE	DESCRIPTION
A	21.08.17	INITIAL ISSUE	MS	TC			



DRAWING DESCRIPTION	MASH TL3 SKT TERMINAL (MSKT)			
DRAWING REFERENCE	K-MSKT TL3	DRAWN BY	M. SEAL	DIMENSIONS
		CHECKED	H. WALLACE	SCALE
		APPROVED	T. COLQUHOUN	mm
				NTS

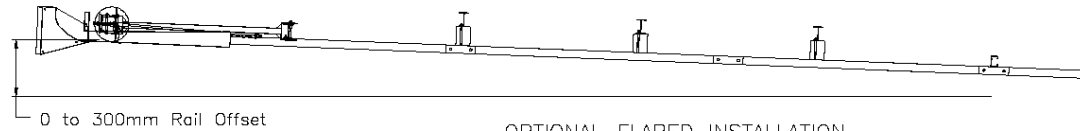
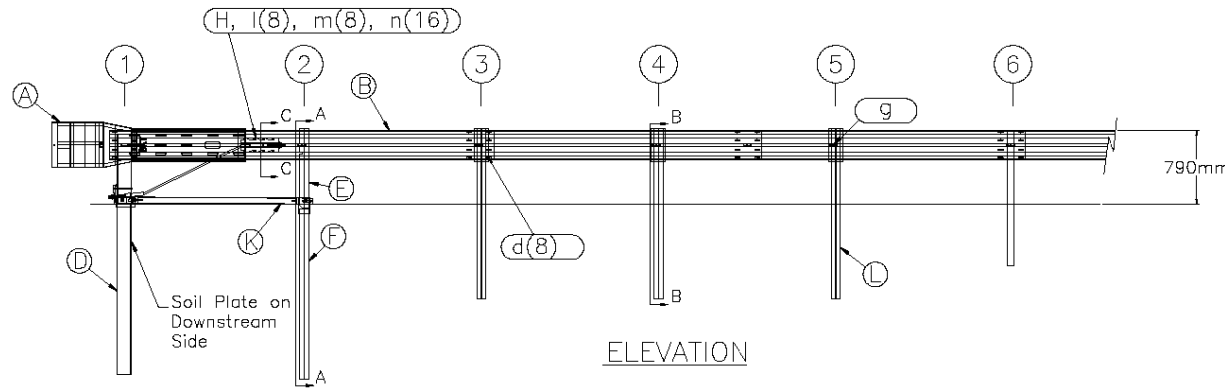
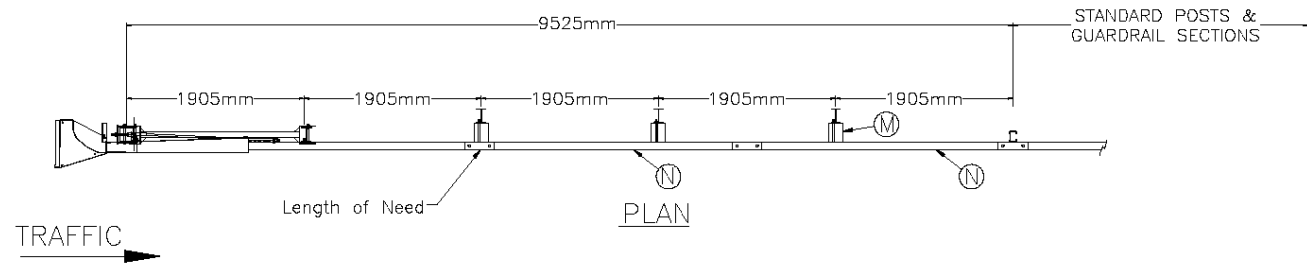

ITEM	QTY	BILL OF MATERIALS	ITEM NO.
A	1	SKT IMPACT HEAD	GE-EF-MX-3333-BG
B	1	SLOTTED ANCHOR RAIL 3810	GE-WB-SR-3810-BG
C	1	TOP POST 1	GE-PG-IS-0650-CG
D	1	BOTTOM POST 1	GE-PG-IS-1900-CG
E	1	TOP POST 2	GE-PG-IS-0860-AG
F	1	BOTTOM POST 2	GE-PG-IS-1950-AG
G	1	BEARING PLATE	GE-EF-MX-0011-AG
H	1	ANCHOR CABLE BRACKET	GE-EF-MX-0015-AG
J	1	CABLE ASSEMBLY	GE-EF-MX-2000-AG
K	1	GROUND STRUT	GE-EF-MX-4020-BG
L	3	STEEL LINE POST	GE-PG-IS-1830-CG
M	3	COMPOSITE BLOCK	GE-BL-SS-0310-AS
N	2	W-BEAM GUARDRAIL 2860mm	GE-WB-SR-2860-AG
HARDWARE			
a	2	M8 x 25mm HEX BOLT	GE-FS-08-0025-HG
b	4	M8 WASHER	GE-FS-08-0000-AG
c	2	M8 NUT	GE-FS-08-0000-HG
d	25	M16 x 32mm SPLICE BOLT/NUT	GR-FS-16-0032-MG
e	2	M16 x 220mm BOLT / NUT	GE-FS-16-0220-HG
f	4	M16 WASHER	GE-FS-16-0000-CG
g	3	5/8" x 10" POST BOLT / NUT	GE-FS-58-0010-MG
h	1	M20 x 220mm BOLT / NUT	GE-FS-20-0220-HG
j	2	M20 WASHER	GE-FS-20-0000-BG
k	1	BEARING PLATE RETAINER TIE	GE-MX-MX-0011-AS
l	8	1/2" x 1 1/4" SHOULDER BOLT	GE-FS-12-0114-HG
m	8	1/2" SHOULDER BOLT NUT	GE-FS-12-0000-HG
n	16	1/2" SHOULDER BOLT WASHER	GE-FS-12-0000-AG

NOTES:

1. THE LOWER SECTIONS OF POSTS 1 & 2 SHALL NOT PROTRUDE MORE THAN 100mm ABOVE GROUND.
2. THE CABLE ASSEMBLY MUST BE TAUT.

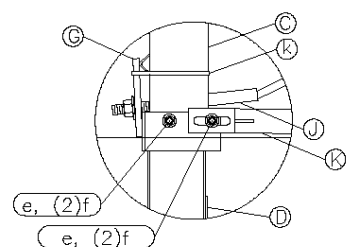

Post #1 Connection Detail

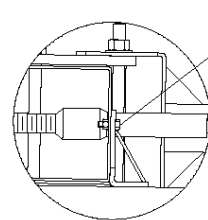

Impact Head Connection Detail

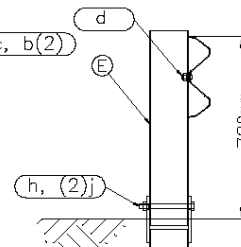

SECTION A-A
Post #2

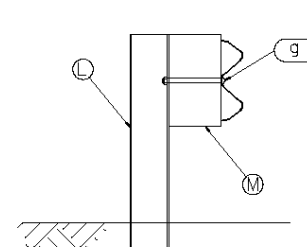

SECTION B-B
Posts #3 thru #5

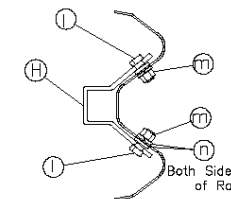

SECTION C-C
Anchor Bracket

REV	DATE	DESCRIPTION	DRAWN	APPRD.	REV	DATE	DESCRIPTION	DRAWN	APPRD.
A	21.08.17	INITIAL ISSUE	MS	TC					



DRAWING DESCRIPTION
DRAWING REFERENCE

MASH TL2 SKT TERMINAL (MSKT)			
K-MSKT TL2	DRAWN BY M. SEAL	DIMENSIONS mm	
	CHECKED H. WALLACE	SCALE NTS	
	APPROVED T. COLQUHOUN		



SafeDirection

CRASH BARRIER SOLUTIONS



Safe Direction Pty Ltd

Unit 2, 5 Simpson Close, Smeaton Grange NSW 2567 Australia

Ph: 1300 063 220 | E: sales@safedirection.com.au

safedirection.com.au

ABN 53 156 459 684